

多量程台式 DC 电源

PSB-2000 系列

使用手册

固纬料号 NO.



ISO-9001 认证企业

GW INSTEK

版权声明

本手册所含资料受到版权保护，未经固纬电子实业股份有限公司预先授权，不得将手册内任何章节影印、复制或翻译成其它语言。

本手册所含资料在印制之前已经过校正，但因固纬电子实业股份有限公司不断改善产品，所以保留未来修改产品规格、特性以及保养维修程序的权利，不必事前通知。

固纬电子实业股份有限公司
新北市土城区中兴路 7-1 号

目录

安全说明	5
产品介绍	錯誤! 尚未定義書籤。
PSB-2000 系列介绍	10
外观	18
操作	33
连接 AC 电源线	33
将负载接至输出端	33
操作量程(PSB-2400L, 2800L, 2400L2, 2800LS)	40
操作量程(PSB-2400H, 2800H)	41
多种设置	42
菜单键功能	48
电压传感	68
外部控制功能	70
使用序列功能	80
其它功能	82
显示报警状态	82

机框连接控制并联操作(除 PSB-2400L2)	83
机框连接控制串联操作(除 PSB-2400L2, PSB-H)	85
使用 PSB-2800LS 扩大功率(仅并联)	86
使用 PSB-007 连接套件	87
外部控制	92
远程控制	92
接口连接	93
PSB-001 规格(选配).....	93
PSB-002 规格(标配).....	94
连接方式	95
连接线	97
地址设置	98
使用接口板	101
通信指令	104
寄存器	129
附录	139
故障排除	139
维修	錯誤! 尚未定義書籤。
尺寸	錯誤! 尚未定義書籤。
规格	145
Declaration of Conformity.....	161

安全说明

本章节包含操作和存储时必须遵照的重要安全说明。在操作前请仔细阅读以下内容，确保安全和最佳化的使用。

安全符号

这些安全符号会出现在本使用手册或仪器上。



警告

警告: 产品在某一特定情况下或实际应用中可能对人体造成伤害或危及生命



注意

注意: 产品在某一特定情况下或实际应用中可能对产品本身或其它产品造成损坏



高压危险



请参考使用手册



保护导电端子



接地端子



勿将电子设备作为未分类的市政废弃物处理。请单独收集处理或联系设备供应商

安全指南

通常



- 勿将重物置于仪器上
- 避免严重撞击或不当放置而损坏仪器
- 避免静电释放至仪器
- 请勿阻止或妨碍风扇通风
- 请勿测量直接与总电源相连的电路
- 若非专业技术人员，请勿自行拆装仪器

(测量等级) EN 61010-1:2001 规定了如下测量等级，该仪器属于等级 I:

- 测量等级 IV: 测量低电压设备电源
- 测量等级 III: 测量建筑设备
- 测量等级 II: 测量直接连接到低电压设备的电路
- 测量等级 I: 测量未直接连接电源的电路

电源



- AC 输入电压: 100VAC~240VAC, 1300VA Max
- 频率: 50Hz/60Hz
- 将交流电源插座的保护接地端子接地，避免电击触电

清洁

- 清洁前先切断电源
- 以中性洗涤剂 and 清水沾湿软布擦拭仪器。不要直接将任何液体喷洒到仪器
- 不要使用含苯，甲苯，二甲苯和丙酮等烈性物质的化学药品或清洁剂

操作环境

- 地点: 室内，避免阳光直射，无灰尘，无导电污染(下注)
 - 相对湿度: 30%~80% (无凝结)
 - 海拔: < 2000m
 - 温度: 0°C~40°C
-

(污染等级) EN 61010-1:2001 规定了如下污染程度。该仪器属于等级 2:

污染指“可能引起绝缘强度或表面电阻率降低的外界物质, 固体, 液体或气体(电离气体)”。

- 污染等级 1: 无污染或仅干燥, 存在非导电污染, 污染无影响
- 污染等级 2: 通常只存在非导电污染, 偶尔存在由凝结核引起的短暂导电
- 污染等级 3: 存在导电污染或由于凝结核原因使干燥的非导电性污染变成导电性污染。此种情况下, 设备通常处于避免阳光直射和充分风压条件下, 但温度和湿度未受控制

存储环境

- 地点: 室内
- 相对湿度: 30%~70% (无凝结)
- 温度: -20°C~70°C

英制电源线

在英国使用时，确保电源线符合以下安全说明。

注意：导线/设备连接必须由专业人员操作



警告：此装置必须接地

重要：导线颜色应与下述规则保持一致：

绿色/黄色： 接地

蓝色： 零线

棕色： 火线(相线)



导线颜色可能与插头/仪器中所标识的略有差异，请遵循如下操作：

颜色为绿色/黄色的线需与标有字母“E”，或接地标志⊕，或颜色为绿色/黄绿色的接地端子相连；

颜色为蓝色的线需与标有字母“N”，或颜色为蓝色或黑色的端子相连；

颜色为棕色的线需与标有字母“L”或“P”，或者颜色为棕色或红色的端子相连。

若有疑问，请参照本仪器提供的用法说明或与经销商联系。

电缆/仪器需有符合额定值和规格的 HBC 保险丝保护：保险丝额定值请参照仪器说明或使用手册。如：0.75mm² 的电缆需要 3A 或 5A 的保险丝。保险丝型号与连接方法有关，大的导体通常应使用 13A 保险丝。

将带有裸线的电缆、插头或其它连接器与火线插座相连非常危险。若已确认电缆或插座存在危险，必须关闭电源，拔下电缆、保险丝和保险丝座，并且根据以上标准立即更换电线和保险丝。

产 品介绍

PSB 系列是一款输出可调、高性能的开关直流电源。内含一个高频电流抑制电路，无需切换即可接收 AC100V~240V 的输入额定电压。在最大额定功率范围内，可提供一个宽广的电压和电流范围。它具有一个可调的定功率功能，还有一些标准特性，如电压和电流设置、输出 On/Off 开关、监控输出和其它经过外部连接端口的功能。体积比传统电源小，减少了整个工作空间。双通道机型和加载机满足更多的应用领域。PSB 系列也能执行序列编程，使用选配接口就可以编写程序。

通过选配接口，用户可以在 PC 机使用 GPIB、RS232C 或 USB 远程控制 PSB 系列。

PSB-2000 系列介绍

产品线

型号	电压范围	电流范围	功率范围
PSB-2400H	0V~800V	0A~3A	0W~400W
PSB-2800H	0V~800V	0A~6A	0W~800W
PSB-2400L	0V~80V	0A~40A	10W~400W
PSB-2800L	0V~80V	0A~80A	10W~800W
PSB-2400L2 (双通道)	0V~80V ×2CH	0A~40A ×2CH	10W~400W ×2CH
PSB-2800LS (加载机)	0V~80V	0A~80A	10W~800W



■ 400W Type
PSB-2400L

■ 800W Type
PSB-2800L



■ 400W×2-Channel Type
PSB-2400L2



■ 800W Type
Booster unit
PSB-2800LS



■ 400W Type
PSB-2400H

■ 800W Type
PSB-2800H

主要特点

多量程输出	在额定电压范围内，电压和电流设置量程多
定功率控制	除定电压(CV)和定电流(CC)控制外，还提供定功率(CP)控制
功率因数校准电路	内置功率因数补偿电路，无需开关切换，兼容从 AC100V~240V 的交流输入电压。它也抑制了谐波电流
可旋转的前面板控制	前面板旋转 90°，仪器可水平或垂直工作
输出 Off Timer 功能	在预设时间结束时，自动关闭输出。这可以避免忘记关闭输出或过量充电
序列(SEQ)功能	序列功能：PC 机执行从选配接口(PSB-001 和 PSB-002)读取的数据。序列功能有两种操作模式：手动模式(逐步执行)和自动模式(最多自动执行 99 步 999 次循环)
保护功能	该电源具有若干保护功能：OVP、OCP 和 OHP。 前面板设置 OVP 和 OCP 保护
预设功能(3 组设置)	直接按 Preset 键选择一个预设值，但需要提前设置
单台控制并联/串联操作	PSB-L 系列使用 1 台电源(作为主机)串并联控制所有与之相连的从属机。最多并联 4 台(含主机)，最多串联 2 台(含主机)

外部控制功能	外部控制功能支持外部电压和电阻控制、电压和电流监控、输出 On/Off 控制、报警输出和 CV/CC 状态输出
--------	---

接口	两种选配接口，可用来远程控制 <ul style="list-style-type: none">• PSB-001: GPIB 和局部总线板• PSB-002: RS-232C, USB 和局部总线板 <p>注：PSB-L 系列的编程序列功能必须使用这些选配接口。更多详情见 80 页</p>
----	--

双通道型号 (PSB-2400L2)	两路 400W 输出通道
-----------------------	--------------

延迟(DLY)功能: (仅 PSB-2400L2)	<ul style="list-style-type: none">• 延迟功能在 Ch 1 和 Ch2 间引入一个切换延迟。 该功能可设置一个上升延迟(时间开启)和一个下降延迟(时间关闭)
------------------------------	---

追踪功能: (仅 PSB-2400L2)	当追踪功能开启时，Ch 2 设置等同于 Ch 1。也就是说，两通道同步改变
-------------------------	---------------------------------------

附件

型号	描述
PSB-001	GPIB 控制板。包括 GRJ-1101 模块线。更多详情见 93 页
PSB-002	RS-232C/USB 控制板。包括 GRJ-1101 模块线。更多详情见 94 页
PSB-003	水平安装并联套件 包括: PSB-007 连接套件, 水平总线 x2, PSB-005 x1

PSB-007 连接套件

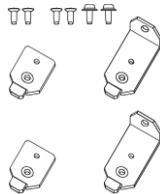

水平总线

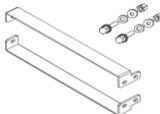

PSB-005



註解 [U]:

PSB-004

垂直安装并联套件

包括: PSB-007 连接套件, 垂直总线 x2, PSB-005 x1

PSB-007 连接套件

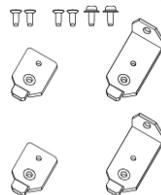

垂直总线

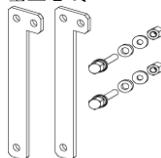

PSB-005



PSB-005

并联信号线



PSB-006

串联信号线



PSB-007

连接套件:

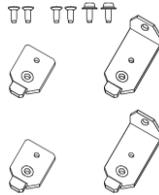
包括 4 个连接板, 4X M3x6
螺丝, 2X M3x8 螺丝

GRJ-1101

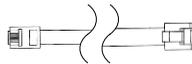
模组线: 500mm 6P6C RJ11
(局部总线)

标配

型号	描述
	使用手册 CD x 1
	AC 电源线 x 1
	后面板输出端螺丝
	后面板输出端保护盖
	前面板输出端保护盖
	外部控制接口(26-pin)
	GND 线

前面板(PSB-2400H)

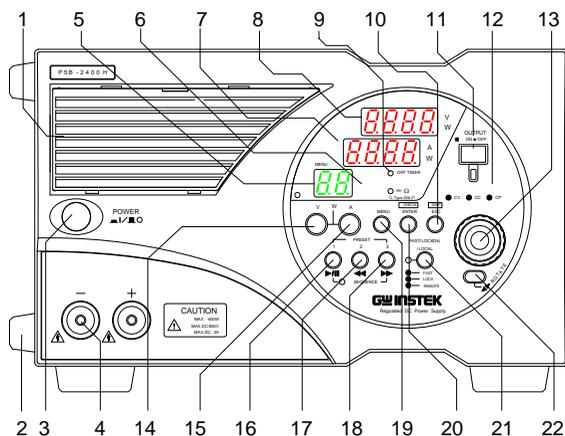

项目	描述
1 Front grill	冷却内部电路的通风网。可拆开，内部有一个滤尘器。见 139 页定时清洁滤尘器
2 Rubber feet	如果支脚不需要，可以拆掉
3 POWER ON/OFF switch	开关(I)位置为开机，再按关机

- 4 Front output terminals. 最大电流 40A(2400L, 2800L, 2400L2, 2800LS), 3A(2400H)或 6A(2800H)

面板操作

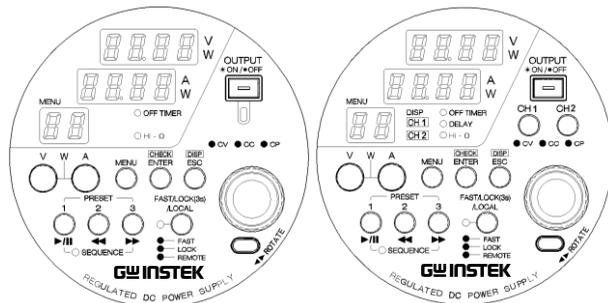

PSB-2400L, PSB-2800L
PSB-2400H, PSB-2800H

PSB- 2400L2

项目	描述			
5 Address no., Step no., cycle no., Menu no.	正常工作	序列操作	菜单	追踪
	无显示	显示步骤或周期数	显示菜单编号	显示“Ab”
6 Channel LEDs	显示所选通道。开启追踪功能后，两个 LED 均变亮			

7 Current LED (7-segment)	正常工作	序列操作	菜单	报警
	显示电流或功率	显示步骤编号	显示设置项	显示 OVP, OCP, HARD 或 OHP

在功率显示状态下，“W” LED 变亮

8 Voltage LED (7-segment)	正常工作	序列操作	菜单	报警
	显示电压或功率	显示周期数	显示设置参数	显示 OVP, OCP, HARD 或 OHP

在功率显示状态下，“W” LED 变亮

9 Function LEDs	显示 OFF TIMER, DELAY 或 Hi Ω 功能的 On/Off 状态。相应功能开启时，LED 呈绿色
-----------------	---

10 ESC/DISP key (ESC / DISP)	改变通道显示、序列操作显示(即 Step No.和 Cycle No.)、Off-timer 的剩余时间和其它显示。当该菜单显示时，按 ESC/DISP 键退出功能选项模式且返回正常模式
------------------------------	---

11 OUTPUT key (red) (OUTPUT)	开启或关闭输出。当输出开启时，LED 变亮
------------------------------	-----------------------

- 12 CH1 and CH2 keys (red, green, orange) (**CH1**, **CH2**)
- 开启或关闭通道输出。相应 LED 颜色表示输出模式
 绿色: CV 模式
 红色: CC 模式
 橙色: CP 模式

仅 PSB-2400L2 的 CH1 和 CH2 键可用。仅 PSB-2400L 和 PSB-2800L 配有一个 LED

- 13 Rotary encoder
- 用于选择功能和改变数值

- 14 V key (green) (**V**)
- 该键用于设置电压。按下并旋转编码器改变设定值。如果 **A** 键和 **V** 键同时按下，两个 LED 灯变亮，此时 LED 进入功率显示模式

- 15 A key (green) (**A**)
- 该键用于设置电流。按下并旋转编码器改变设定值。如果 **A** 键和 **V** 键同时按下，两个 LED 灯变亮，此时 LED 进入功率显示模式

- 16 PRESET 1 key (green) (**PRESET 1**)
- 读取存储在 PRESET 1 中的数据。在序列模式下作为开始/暂停键(**▶||**)使用

- 17 PRESET 2 key (green) (**PRESET 2**)
- 读取存储在 PRESET 2 中的数据。在序列模式下作为返回键(**◀◀**)使用，用于跳过上一步数

- 18 PRESET 3 key (green) 读取存储在 PRESET 3 中的数据。在序列模式下作为前进键(▶)使用, 用于跳过下一步数
 (PRESET 3)
- 19 MENU key 用于设置和选择各种功能
 (MENU)
- 20 ENTER/CHECK Key 在输出值和设定值之间交替工作(与显示)输出开启时, 每按一次 ENTER/ CHECK 键交替显示输出值和设定值
 (ENTER/ CHECK)
- 当 **V** 键点亮, → 开启电压设置
 - 当 **A** 键点亮, → 开启电流设置
 - 当 **V** 和 **A** 键点亮, → 开启功率设置
- 显示菜单时, 按该键确认菜单中的功能和数值
- 21 FAST/LOCK (3s)/LOCAL key (FAST) 改变电压、电流或功率设置的分辨率, 锁定面板操作, 或远程模式切换成本地模式。LED 颜色表示的状态如下:
 FAST (绿): 设置分辨率 1V、1A 或 100W
 LOCK (3s) (红): 前面板操作失效
 REMOTE (橙): 在选配接口板通信时变亮
- 22 ROTATE key PSB-2000 系列的操作面板可以 90° 旋转, 仪器可以水平或垂直使用。按下该键并旋转面板即可

后面板(PSB-2400L2)

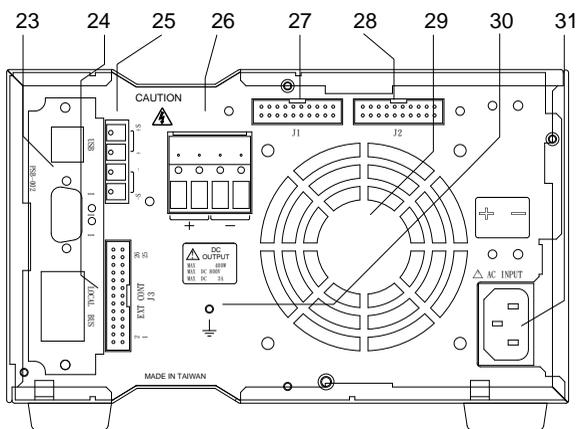
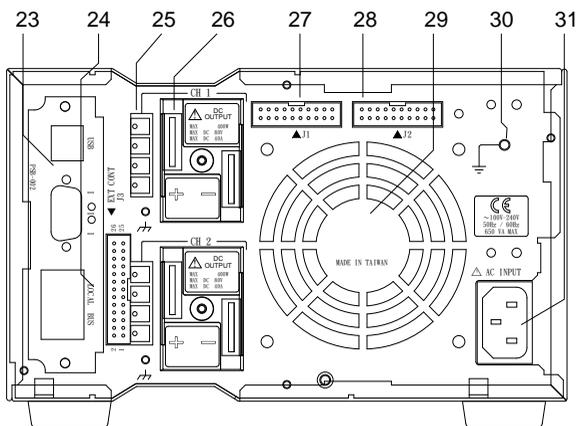

描述

23	Optional Interface board slot	选配接口槽用于安装选配件 PSB-001, 带 GPIB 接口 产品标配 USB/RS-232C
24	J3 external control connector	外部控制接口用于控制或监控不同参数。 管脚分配见 28 页(40A 型号) 31 页(3A/6A 型号)
25	Sensing terminals	传感端子用于改变补偿点。在出厂前传感端子是选择内部短路的。
26	Rear output terminals	PSB-2000 系列电源也可以由该端子输出。后面板输出端类型与型号有关。PSB-2400H 和 PSB-2800H 使用管脚端子; PSB-L 型号使用压接式电压, 可适应更大电流 对于 PSB-2400L2 (双通道), Ch 1 接线盒在后面板上方(CH1), Ch 2 接线盒在后面板下方(CH2)。每个接线盒的正(+)端在左, 负(-)端在右。如果需要底盘接地, 将任意一个输出端与标有接地信号  的螺钉相连即可
27	J1 control signal input connector	用于并联和串联控制。选配机框连接线与该接口相连
28	J2 control signal output connector	用于并联和串联控制。选配机框连接线与该接口相连

-
- | | | |
|----|------------------|---|
| 29 | Exhaust
Grill | 空气从前面进入，由该处排出。后面板请保留至少30cm 空间通风。如果有物体遮挡，会导致仪器内部温度急速上升 |
|----|------------------|---|
-
- | | | |
|----|---|------|
| 30 | \perp
Functional
ground
terminal | 仪器接地 |
|----|---|------|
-
- | | | |
|----|----------|---------|
| 31 | AC INPUT | AC 电源插口 |
|----|----------|---------|

J3 外部控制接口的引脚分配

(PSB-2400L, 2800L, 2400L2, 2800LS)

Pin No.	信号名称	功能
1	CH2 STATUS COM (COM for 2, 3 & 4)	COM Pin 2, 3 和 4
2	CH2 ALARM OUT	开路集电极输出。当 Ch 2 报警, 该 Pin 拉低
3	CH2 EXT CC STATUS OUT	开路集电极输出。当 Ch 2 处于 CC 模式, 设成低电平
4	CH2 EXT CV STATUS OUT	开路集电极输出。当 Ch 2 处于 CV 模式, 设成低电平
5	CH2 EXT CV CONTROL IN	Ch 2 定电压控制输入管脚 在外部电压控制模式下, 0V~10V 的外部电压用于控制 0V~额定输出电压 在外部电阻控制模式下, 0kΩ~10kΩ 的外部电阻用于控制 0V~额定输出电压

6	CH2 EXT CC CONTROL IN	Ch 2 定电流控制输入管脚 在外部电压控制模式下，0V~10V 的外部电压用于控制 0A~额定输出电流 在外部电阻控制模式下，0kΩ~10kΩ 的外部电阻用于控制 0A~额定输出电流
7	CH2 COM	Ch 2 的 COM 管脚 与 Ch 2 的负输出端相连
8	CH2 EXT V MON OUT	Ch 2 的输出电压监控 0V~10V 的输出电压表示 0V~额定输出电压
9	CH2 EXT A MON OUT	Ch 2 的输出电流监控 0V~10V 的输出电压表示 0A~额定输出电流
10	CH2 COM	Ch 2 的 COM 管脚。与 Ch 2 的负输出端相连
11	CH2 EXT ALARM IN	当 Ch 2 COM 管脚短路时开启报警状态
12	CH2 EXT OUTPUT IN	当 Ch 2 COM 管脚短路时开启 Ch 2 输出
13	CH2 COM	Ch 2 的 COM 管脚。与 Ch 2 的负输出端相连

14	CH1 EXT CV CONTROL IN	Ch 1 定电压控制输入管脚 在外部电压控制模式下, 0V~10V 的外部电压用于控制 0V~额定输出电压 在外部电阻控制模式下, 0k Ω ~10k Ω 的外部电阻用于控制 0V~额定输出电压
15	CH1 EXT CC CONTROL IN	Ch 1 定电流控制输入管脚 在外部电压控制模式下, 0V~10V 的外部电压用于控制 0A~额定输出电流 在外部电阻控制模式下, 0k Ω ~10k Ω 的外部电阻用于控制 0A~额定输出电流
16	CH1 COM	Ch 1 的 COM 管脚 与 Ch 1 的负输出端相连
17	CH1 EXT V MON OUT	Ch 1 的输出电压监控管脚 0V~10V 的输出电压表示 0V~额定输出电压
18	CH1 EXT A MON OUT	Ch 1 的输出电压监控管脚 0V~10V 的输出电压表示 0A~额定输出电流
19	CH1 COM	Ch 1 的 COM 管脚 与 Ch 1 的负输出端相连
20	CH1 EXT ALARM IN	当 Ch 1 COM 管脚短路时开启报警状态
21	CH1 EXT OUTPUT IN	当 Ch 1 COM 管脚短路时开启 Ch 1 输出

22	CH1 COM	Ch 1 的 COM 管脚 与 Ch 1 的负输出端相连
23	CH1 EXT CV STATUS OUT	开路集电极输出。当 Ch 1 处于 CV 模式，设成低电平
24	CH1 EXT CC STATUS OUT	开路集电极输出。当 Ch 1 处于 CC 模式，设成低电平
25	CH1 ALARM OUT	开路集电极输出。当 Ch 1 处于报警模式，设成低电平
26	CH1 STATUS COM (COM of 23, 24 & 25)	COM Pin 23, 24 和 25

J3 外部控制接口的引脚分配(PSB-2400H, 2800H)

Pin No.	信号名称	功能
13	NC	
14	EXT CV CONTROL IN	定电压控制输入管脚 在外部电压控制模式下，0V~10V 的外部电压用于控制 0V~800V 输出电压 在外部电阻控制模式下，0kΩ~10kΩ 的外部电阻用于控制 0V~800V 输出电压

15	EXT CC CONTROL IN	定电流控制输入管脚 在外部电压控制模式下，0V~10V 的外部电压用于控制 0A~3A(400H)或 6A(800H)输出电流 在外部电阻控制模式下，0kΩ~10kΩ 的外部电阻用于控制 0A~3A(400H)或 6A(800H)输出电流
16	COM	COM 与负输出端相连
17	EXT V MON OUT	输出电压监控管脚 0V~10V 的输出电压表示 0V~800V 输出电压
18	EXT A MON OUT	输出电流监控管脚 0V~10V 的输出电压表示 3A(400H)或 6A(800H)输出电流
19	COM	COM 与负输出端相连
20	EXT ALARM IN	当 COM 管脚短路时开启报警状态
21	EXT OUTPUT IN	当 COM 管脚短路时开启输出
22	COM	COM 与负输出端相连
23	EXT CV STATUS OUT	开路集电极输出。当 Ch 处于 CV 模式， 设成低电平

24	EXT CC STATUS OUT	开路集电极输出。当 Ch 处于 CC 模式， 设成低电平
25	ALARM OUT	开路集电极输出。当 Ch 处于报警模式， 设成低电平
26	STATUS COM	COM Pin 23, 24 和 25

操作

本章节介绍开机步骤和准备工作。

连接 AC 电源线

介绍

- 确保仪器关机
- 使用配套的 AC 电源线
- 将 AC 电源线接入后面板 AC INPUT 插口

将负载接入输出端

介绍

使用额定电压超过地电压(500V)的连接线
前输出端与后输出端内部是电气性连接。当使用前
输出端时，后输出端也是可用的。使用配套的保护
盖，避免后输出端引发的触电



注意

当 POWER 开关关闭时，确保仅连接负载
连接负载所使用的接线需要有足够大的电流容量，

否则可能导致火灾。

如果为了减少噪声或避免故障而将接线扭合在一起，那么需要使用更大电流容量的线缆

Be careful of the temperature!



连接后输出端(PSB-2400L, 2800L, 2400L2, 2800LS)

- 步骤
1. 从 AC INPUT 插口拔掉 AC 电源线
 2. 将输出端与负载线末端相连。使用配套的螺母拧紧接线片



注意

后输出端有 M6 孔和 M3 (tapped) 孔。确保与负载相连的是 M6 孔。可以通过扭合负载线或将一个薄膜电容器(几 μF , 低阻抗, 高频)和一个电解质电容器(几百 μF)与负载末端相连来降低负载末端的噪声。

Fig. 连接后输出端

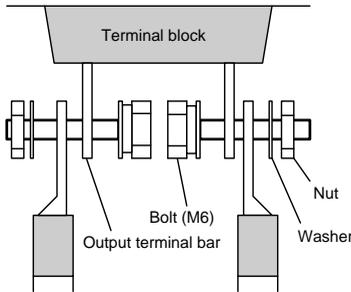



注意

使用上述电源提供的螺栓连线。如果使用不同的螺栓，可能会触碰保护盖或干扰保护盖。接线片端一定是在输出端外面。

3. 使用 GND 线将正或负输出端与 GND 符号相连



注意

外部电压控制管脚的负电位与负输出端一致。如果电源正极接地且外部控制电源的负端接地，那么用于外部电压控制的负载线将短路电源输出，这会损坏电源。此时，确保外部电压控制源随输出端浮动。

Fig. 正接地连接

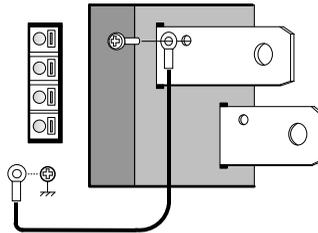

Connect with this screw

4. 将输出端子和负载线夹入输出保护盖,如下所示. 将螺钉拧进保护盖

Fig. 合上后输出
端保护盖

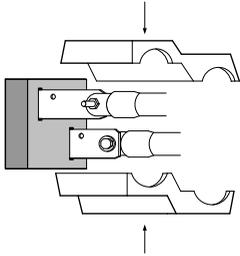

 注意

即使端子未使用，也请合上保护盖。

前和后输出端内部电气性连接。接触未保护端子可能导致电击。

后输出端有 M6 孔和 M3 (tapped) 孔。确保与负载相连的是 M6 孔。可以通过扭合负载线或将一个薄膜电容器(几 μF , 低阻抗, 高频)和一个电解质电容器(几百 μF)与负载末端相连来降低负载末端的噪声。

5. 用剪钳等切断如下阴影部分，将串联或并联电源连接接地输出

Fig. 切断部分

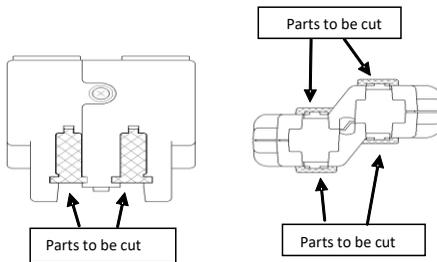

连接后面板输出端子(PSB-2400H, 2800H)

- 步骤
1. 从 AC INPUT 拔掉 AC 线
 2. 插入负载线，使用一字螺丝刀或相似工具固定
 3. 如有需要，使用提供的输出接地线和螺钉，将正或负接地接到输出接地端(⏏符号)



注意

可以通过扭合负载线或将一个薄膜电容器(几 μF , 低阻抗, 高频)和一个电解质电容器(几百 μF)与负载末端相连来降低负载末端的噪声。

Fig. 连接后输出
端

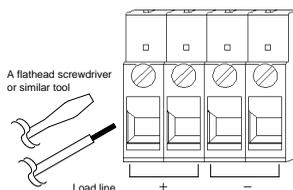

注意

外部电压控制的负电位与负输出端一致。如果电源正极接地且外部控制电源的负端接地，那么用于外部电压控制的负载线将短路电源输出，这会损坏电源。此时，确保外部电压控制源随输出端浮动。

Fig. 正接地连接

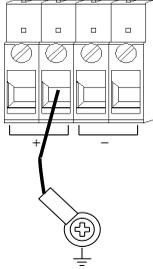

注意

前和后输出端内部电气性连接。未使用的端子仍携带输出电压。

请勿触碰端子，否则会导致电击。

连接前面板输出端子(PSB-2400L, 2800L, 2400L2, 2800LS)

步骤

1. 使用 POWER 开机
2. 将输出接线片与负载线末端相连。固定负载线，消除前输出端和负载线间的不良连接
3. 如果电流从后输出端输出，在前输出端盖上保护盖

Fig. 连接前输出端

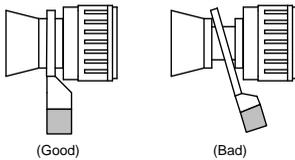



注意

- 电源前输出端最大输出 40A。输出大电流时请勿使用三脚插头或香蕉头插头，避免由于接触电阻导致过热。使用满足输出电流规格的接线片，并将它们固定到前输出端
- 出于安全考虑，绝不要同时在前和后输出端输出电压

安装和连接前输出端插头(PSB-2400H, 2800H)

步骤

1. 将负载线插入插头
2. 使用 1.5 mm 的六角扳手固定 2 个螺丝
3. 合上盖子(completion image)
4. 关闭电源开关
5. 将上面提到的插头插入前输出端
6. 当后输出端流经电流，必须拔掉前输出端的插头

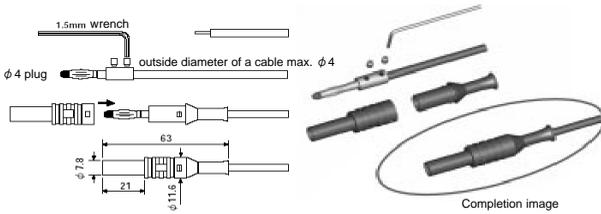

Fig. 前输出端插头的装配图



注意

为确保安全，前后输出端请勿同时使用

工作范围(PSB-2400L, 2800L, 2400L2, 2800LS)

介绍 PSB-2000 系列相较传统电源，在相同额定功率范围内电压和电流设置范围更宽。

- 电压设置范围: 0V~80V (所有型号)
- 电流设置范围: 0A~40A (PSB-2400L & PSB-2400L2)
0A~80A (PSB-2800L & PSB-2800LS)
- 功率设置范围: 10W~400W (PSB-2400L & PSB-2400L2)
10W~800W (PSB-2800L & PSB-2800LS)

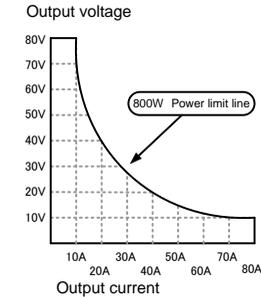
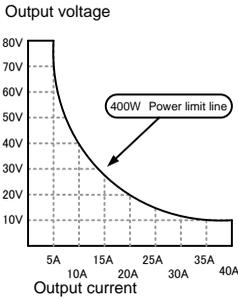

Fig. PSB-2400L/L2 工作范围

Fig. PSB-2800L/LS 工作范围

工作范围(PSB-2400H, 2800H)

- 电压设置范围: 0V~800V (所有型号)
- 电流设置范围: 0A~3A (PSB-2400H)
0A~6A (PSB-2800H)
- 功率设置范围: 0W~400W (PSB-2400H)
0W~800W (PSB-2800H)

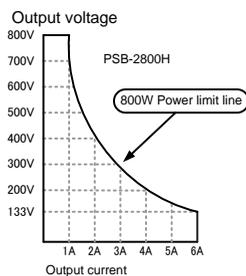
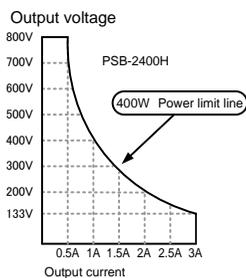

Fig. PSB- 2400H 工作范围

PSB-2800H 工作范围

多种设置

开机

介绍 按 POWER 键开机。电源显示开机画面(固件版本和型号)和关机前的设定值。



注意

当拔掉电源或按 POWER 关机时，电源自动保存最后一次设定值

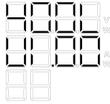

型号 PSB-2400L, 版本 1.00

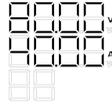

显示最后一次设置

如何设置电压

步骤

1. 确认  键是否呈绿色。如果不是，按  键

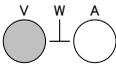

2. 转动旋钮设置电压值

注意

设置 PSB-2400L2 电压值前需确认所选通道，避免改动其它通道设置

如何设置电流

- 步骤 1. 确认 **A** 键是否呈绿色。如果不是，按 **A** 键

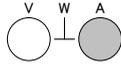

2. 转动旋钮设置电流值

如何设置功率

- 步骤 1. 确认 **V** 和 **A** 键变亮。如果不是，按 **V** 和 **A** 键。
(设置功率时，两个键需要被点亮)

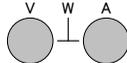

如果在已按 **V** 键的同时再按 **A** 键，当前 LED 则表示功率设置(“A”指示灯关闭，“W”指示灯开启，表示从电流设置转至功率设置)。见下图“电压和功率”

如果在已按 **A** 键的同时再按 **V** 键，当前 LED 则表示功率设置(“V”指示灯关闭，“W”指示灯开启，表示从电压设置转至功率设置)。见下图“电流和功率”

2. 转动旋钮设置功率值

Fig. 功率显示

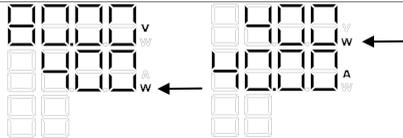

电压和功率:
80V 和 400W

电流和功率:
400W 和 40A

如何开启输出

<p>输出方式</p>	<ul style="list-style-type: none"> • 使用 OUTPUT 键开启或关闭输出 • 使用 CH1 或 CH2 键开启或关闭输出(仅 PSB-2400L2) • 使用外部控制功能开启或关闭输出
<p>注意</p>	<p>如果关闭输出后再快速开启，电压可能不会正常放电。请在关机至少 1s 后再开机</p>
<p>步骤</p>	<ol style="list-style-type: none"> 1. 使用 OUTPUT 键开启或关闭输出 按 OUTPUT 键开启或关闭输出。该键变亮时输出开启。对于 PSB-2400L2，按 OUTPUT 键同时开启或关闭 Ch 1 和 Ch 2 输出。但是可事先按 CH1 CH2 键选择 Ch 1 或 Ch 2 2. 使用 CH1 CH2 键开启或关闭输出(仅 PSB-2400L2) CH1 和 CH2 键相互独立，按 CH1 或 CH2 键可以开启 Ch 1 或 Ch 2 的输出。前提是必须首先点亮 OUTPUT 键
<p>注意</p>	<p>对于 PSB-2400L2，如果 CH1 和 CH2 键都未点亮，即使按 OUTPUT 键也不会输出(不提供输出)</p>

Fig. 按 **OUTPUT** 键输出

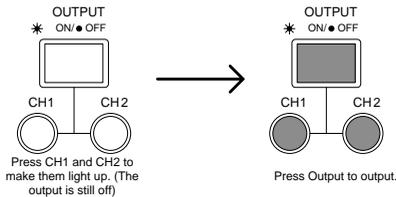

开启输出时如何显示设定值

输出方式 当输出开启，按 **ENTER**/**CHECK** 键切换成显示设定值模式。

步骤 按 **ENTER**/**CHECK** 键在设置模式和输出模式之间切换。

输出开启且处于设置模式时，**A** 或 **V** 键闪烁



注意

在设置模式，如果转动旋钮，设定值改变。在输出模式，如果转动旋钮，输出值改变。请勿触摸旋钮核查设定值

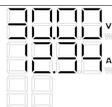

输出值

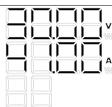

按 CHECK:
设置数值

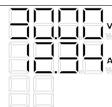

按 CHECK:
输出值

如何 90° 旋转显示面板

PSB-2000 系列的显示面板可以 90° 旋转，进行水平或垂直工作。按住旋钮下方的 ROTATE 键旋转面板方向，直到听见“滴答”声，表示面板已锁定到当前位置。



注意

在旋转面板前，确保 POWER 键关闭。
如果开机中旋转面板，设定值可能会因为旋钮转动而改变

Fig. 旋转显示面板

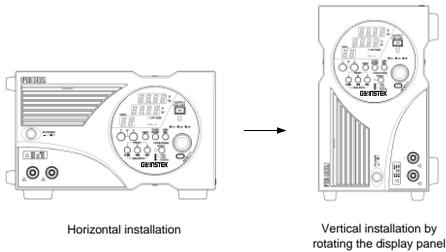

如何关闭面板操作(按键锁定功能)

操作 按旋钮左侧的 FAST/LOCK(3s)/LOCAL 键超过 3s 锁定前面板键，当旁边的键变红时，锁定成功。再按 FAST/LOCK(3s)/LOCAL 键超过 3s 取消锁定。



注意

该键负责 FAST、LOCK (3s)和 LOCAL 功能。当电源处于锁定状态时，它将自动取消 FAST 模式设置(如果设置)并将电源恢复至 SLOW 模式

在锁定状态下，OUTPUT 键仍可以使用

菜单键功能

介绍

- 按 **MENU** 键改变菜单编号:
 - PSB-2400L, 2800L, 2800LS: **MENU** 选择“01”~“07”
 - PSB-2400L2: **MENU** 选择“01”~“09”
 - PSB-2400H, 2800H: **MENU** 选择“01”~“06”
- 按 **ESC/ DISP** 键从 **MENU** 设置返回至正常设置
- 若需取消某功能, 再从菜单键选择相应设置并取消

操作概述

- MENU** 键: 通过菜单选项循环
- ENTER/ CHECK** 键: 确认数值和项目
- ESC/ DISP** 键: 退出菜单设置并返回正常设置
- 旋钮: 选择数值和项目

菜单操作请参考下图:

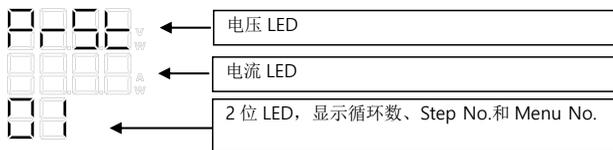

- 一般设置步骤
1. 按 **MENU** 键直至显示预期功能编号
 2. 按 **ENTER** / **CHECK** 键确认, 进入下一步设置
 3. 用旋钮设置数值或项目, 按 **ENTER** / **CHECK** 键确认
 4. 所有项目设置完成, 按 **ESC** / **DISP** 键回到正常状态



注意

按 ENTER / CHECK 键仅用于确认设定值
 请确认正确的设定值
 不能被同时设置和使用的功能如下:

设置功能	不能被同时设置或使用的功能
预设	序列 外部(电压/电阻)
OVP/OCP	-
Hi-Ω (仅 PSB-L 系列)	-
关闭计时器	序列延迟 外部(On/Off)
序列	预设 关闭计时器 外部(电压/电阻) 外部 (On/Off) 延迟 追踪
外部(电压/电阻)	预设 追踪
外部(On/Off)	关闭计时器 延迟
延迟(仅 PSB-L 系列)	序列 关闭计时器
追踪 (仅 PSB-L 系列)	序列 外部(电压/电阻) 外部 (On/Off)

预设功能

菜单项: 01(所有型号)

介绍 该功能可将如下三种设置保存到 PRESET 键。注：
其它设置/值不能保存

- 设置电压
- 设置电流
- 设置功率

步骤

1. 设置需要保存的电压/电流/功率

2. 按 **MENU** 键直至显示菜单编号“01”

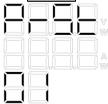

3. 按 **ENTER**/**CHECK** 键。所有 PRESET 键闪烁绿色

4. 按任意一个 PRESET 键，此时该键绿色不再闪烁，表示保存成功

5. 按 **ESC**/**DISP** 键返回正常操作



注意

只要按 **MENU** 键开启预设功能，就不能再设置电压、电流和功率

OVP/OCP 功能

菜单项: 02 (所有型号)

介绍

- OVP: (过电压保护)
当 PSB-2000 系列输出电压超过预设 OVP 值时，OVP 功能将输出关闭

型号	设置范围	分辨率
PSB-2400L PSB-2800L PSB-2400L2 PSB-2800LS	1.0V~84.0V	0.1V
PSB-2400H PSB-2800H	10.0V~840.0V	1V

- OCP: (过电流保护)
当 PSB-2000 系列输出电流超过预设 OCP 值时，OVP 功能将输出关闭

型号	设置范围	分辨率*
PSB-2400L PSB-2400L2	1.0A~42.0A	0.1A
PSB-2800L	1.0A~84.0A	0.1A
PSB-2400H	0.1A~3.15A	0.01A
PSB-2800H	0.1A~6.30A	0.01A

*并联/串联操作的分辨率不同，详情见规格

步骤

1. 按 **MENU** 键直至显示菜单编号“02”

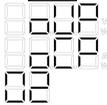

2. 按 **ENTER**/**CHECK** 键在 OVP 和 OCP 设置之间切换。对于 PSB-2400L2，首先显示 Ch 1 的 OVP 和 OCP 设置，其次是 Ch 2

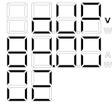

OVP setting

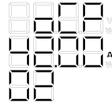

OCP setting



CH 1 的 OVP 和 OCP 设置



CH 2 的 OVP 和 OCP 设置

3. 当显示保护功能时(OVP 或 OCP)，转动旋钮设置 OVP 或 OCP 值
4. 按 **ENTER/** **CHECK** 键确认。设置完成
5. 按 **ESC/** **DISP** 键返回正常操作

Hi-Ω-功能

菜单项: 03 (仅 PSB-L 系列)

介绍

PSB-2000 系列的滤波电容与输出相连。输出关闭时，PSB-L 电源的分压电路将这些电容放电至一个安全准位。当开启 Hi-Ω 功能，分压电路关闭。当分压电路开启时，用户可以忽略反向电流，保护给电池或电容充电的二极管。

开启 Hi-Ω 功能时，内部滤波电容在电源关闭后仍带电，这是相当危险的。作为安全设计，在输出关闭后，分压电路开启一段预设时间(5 ~ 30 min)。

步骤

1. 按 **MENU** 键直至显示菜单编号“03”

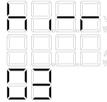

2. 按 **ENTER** / **CHECK** 键进入 Hi-Ω 功能设置模式。用旋钮选择 ON 或 OFF。Hi-Ω 功能默认 OFF

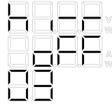

Hi-Ω Off

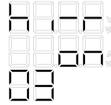

Hi-Ω On

3. 按 **ENTER** / **CHECK** 键确认设置
面板中心的 Hi-Ω LED 开启
 - OFF TIMER
 - DELAY
 - Hi-Ω
4. 用旋钮设置分压电路开启的时间限制
设置范围: 5~30 min
设置分辨率: 5 min 步进

按 **ENTER** / **CHECK** 键确认设置

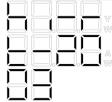

例如: 时间设为 20 min

5. 按 **ESC** / **DISP** 键退出设置模式, 返回正常操作



注意

Hi-Ω 功能开启时, 即使在输出关闭后, 电源输出端仍继续传输电压。

由于内部电容仍旧带电, Hi-Ω 功能处于开启状态, Hi-Ω LED 闪烁。当关闭输出, 输出端电压可能继续维持在 80V 电压, 此时非常危险。为避免这种情况, 用继电器或开关彻底隔离输出端与负载线。

关闭计时器功能

菜单项: 04(PSB-L 系列), 03(PSB-H 系列)

介绍 在一段时间后自动关闭输出。计时器以 10 min 步进，最大可设至 99 h 50 min。

步骤

1. 按 **MENU** 键直至显示菜单编号“04”(PSB-L)或“03”(PSB-H 系列)

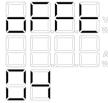

2. 按 **ENTER** / **CHECK** 键进入 Off Timer 设置

3. 用旋钮选择 ON 或 OFF。Off Timer 默认 OFF

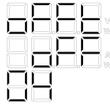

Initial setting

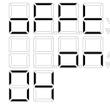

OFF timer activated

4. 按 **ENTER** / **CHECK** 键确认设置
当开启计时器，面板中心的 OFF TIMER LED 变亮

- OFF TIMER
- DELAY
- Hi-Ω

5. 用旋钮设置计时时间
按 **ENTER** / **CHECK** 键确认设置
计时器以 10 min 步进，最大可设至 99 h 50 min。当剩余时间少于 5 min，OFF TIMER LED 闪烁
当运行 off-timer 时，按 ESC/DISP 键可以核查

剩余时间(对于 PSB-2400L2, 按 ESC/DISP 键切换显示顺序: CH1 设置, CH2 设置, off-timer 剩余时间)

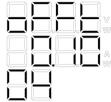

例如: Off Timer 设为 10 min

- 按 **ESC** / **DISP** 键退出设置菜单, 返回正常操作

序列功能

菜单项: 05(PSB-L), 04(PSB-H)

介绍

该功能可执行序列编程。请注意，仅当安装了接口板(PSB-001 或 PSB-002)时，才可以创建序列功能。若没有安装接口板，序列功能不可用。如何编程序列，请见 PSB_Sequence_203 使用手册或 GW Instek 网站。

以下描述 如何在以前创建的序列查看步骤和 在电脑上运用 “PSB_Sequence_203” 应用用以创建序列

注：PSB 系列不能编辑或创建序列

Fig. 重复 3 次
Step 20~22.
起始步 Step 20

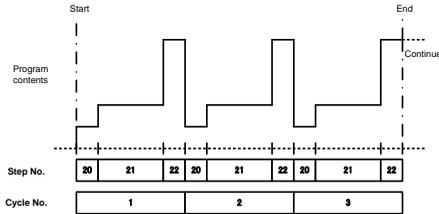

注意

如上图所示，若编程结束时输出处于开启状态，那么即使完成序列操作，电源输出仍保留在最后一步的准位上(即输出保持开启)。若需在序列结束时关闭输出，最后一步必须设成 OFF。

如果在序列运行时按下 OUTPUT 键，序列操作将提早结束。但此时电源维持在最后一步的输出准位上。

步骤

1. 按 **MENU** 键直至显示菜单编号“05”(PSB-L)或“4”(PSB-H)

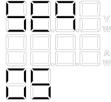

2. 按 **ENTER/CHECK** 键进入序列操作设置。用旋钮选择 ON 或 OFF。默认关闭序列功能

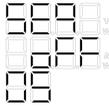

Initial setting

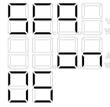

Sequence operation
activated

3. 按 **ENTER/CHECK** 键确认设置
在 PRESET 键下方的 SEQUENCE LED 开启

1 2 3



—●SEQUENCE—

4. 用旋钮设置起始步
按 **ENTER/CHECK** 键确认
设置范围从 0~99

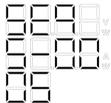

例如: 起始步设为“00”

5. 用旋钮设置结束步
按 **ENTER/CHECK** 键确认

设置范围从 0~99

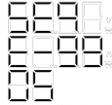

例如: 结束步设为“99”

6. 用旋钮设置步骤的循环次数
按 **ENTER** / **CHECK** 键确认。序列设置完成。

“---”表示无限次重复
设置范围从 1~999 或“—”
(无限)

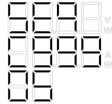

例如: 所选步骤重复 999 次

7. 按 **ESC** / **DISP** 键放弃序列设置并进入序列操作模式

外部控制(外部电压, 外部电阻)

菜单项: 06(PSB-L), 05(PSB-H)

介绍

- 使用外部电压进行定电压(CV)控制

通过使用外部电压可以控制 PSB-2000 系列电源的电压。0V~10V 的外部电压能控制 0V~额定输出电压

- 使用外部电压进行定电流(CC)控制

通过使用外部电压可以控制 PSB-2000 系列电源的电流。0V~10V 的外部电压能控制 0A~额定输出电流

- 使用外部电阻进行定电压(CV)控制

通过连接外部电阻可以控制 PSB-2000 系列电源的电压。0Ω~10kΩ 的外部电阻能控制 0V~额定输出电压

- 使用外部电阻进行定电流(CC)控制

通过连接外部电阻可以控制 PSB-2000 系列电源的电流。0Ω~10kΩ 的外部电阻能控制 0A~额定输出电流



注意

PSB-2000 系列电源不能同时进行外部电压和外部电阻控制。

例如: 不支持外部电压的 CV 控制和外部电阻的 CC 控制。

步骤

1. 按 **MENU** 键直至菜单显示“06”(PSB-L)或“05”(PSB-H)

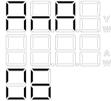

2. 按 **ENTER/CHECK** 键进入外部控制设置。用旋钮选择外部电压或外部电阻，并按 **ENTER/CHECK** 键。默认关闭外部控制

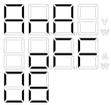

无限设置

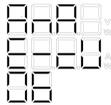

外部电压

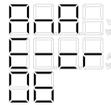

外部电阻

3. 用旋钮选择外部控制模式

模式如下:

CV= 定电压

CC= 定电流

IN = 前面板控制或 PC 远程控制

OUT= 使用外部控制

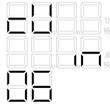

前面板控制定电压

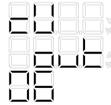

外部控制定电压

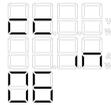

前面板控制定电流

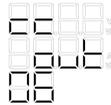

外部控制定电流

4. 按 **ENTER** / **CHECK** 键确认
控制模式设置完成

5. 按 **ESC** / **DISP** 键退出设置模式并返回正常操作

外部控制 On/Off 输出

菜单项: 07(PSB-L, 06(PSB-H)

介绍

将外部控制接口的某几个管脚短路(output on)或开路(output off), PSB 系列可以外部控制输出的开启或关闭。

选择用外部控制或 OUTPUT 键来开启输出。

步骤

1. 按 **MENU** 键直至菜单显示“07”(PSB-L)或“06”(PSB-H)

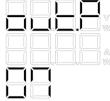

2. 按 **ENTER**/**CHECK** 键进入外部输出 On/Off 控制设置模式

3. 用旋钮选择 On 或 Off, 再按 **ENTER**/**CHECK** 键确认。外部输出 On/Off 设置完成。输出控制模式如下:

IN= 输出由 OUTPUT 键控制

OUT= 输出由外部控制

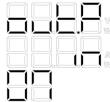

OUTPUT key control

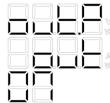

External Control

4. 按 **ESC**/**DISP** 键退出设置并返回正常操作

延迟控制

菜单项: 08 (PSB-L2)

介绍 延迟功能仅限两通道机型(PSB-2400L2)。它在一段指定时间内(几秒), 从某个参考点(Ch 1 输出), 对 Ch 2 输出增加了一个上升和下降的延迟时间。上升延迟时间即延迟开启输出的时间。下降延迟时间即延迟关闭输出的时间。

Fig. 延迟功能

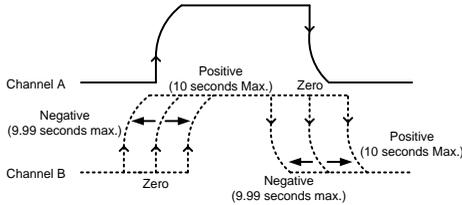

步骤

1. 按 **MENU** 键直至菜单显示“08”



2. 按 **ENTER/CHECK** 键进入延迟功能设置。用旋钮选择 On 或 Off。默认延迟设置关闭



Delay OFF



Delay ON

3. 按 **ENTER/CHECK** 键确认。
面板中间的 DELAY LED 变亮
○ OFF TIMER

- DELAY
- Hi-Ω

4. 用旋钮设置上升延迟时间。当时间设成正值，Ch 2 的输出延迟 Ch 1。反之，当时间设成负值，Ch 2 的输出超前 Ch 1。延迟时间设置范围-9.99 s ~ +10.00 s，步进 10 ms



Ch 2 的输出提前 9.99s 开启 Ch 2 的输出延迟 10.00s 开启

5. 用旋钮设置下降延迟时间，再按 **ENTER** / **CHECK** 键。延迟功能设置完成



Ch 2 的输出提前 9.99s 关闭 Ch 2 的输出延迟 10.00s 关闭

6. 按 **ESC** / **DISP** 键退出延迟设置并返回正常操作

追踪功能

菜单项: 09 (PSB-L2)

介绍 追踪功能仅限两通道机型(PSB-2400L2)。当开启追踪功能, Ch 2 与 Ch 1 的输出保持一致, 称 Ch 2 “追踪” Ch 1。这也就意味着两通道的输出值同时改变。

Fig. 追踪功能

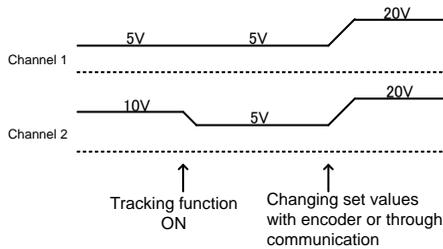

步骤

1. 按 **MENU** 键直至菜单显示“09”
2. 按 **ENTER** / **CHECK** 键进入追踪功能设置模式。用旋钮选择 On 或 Off。默认追踪功能关闭
3. 按 **ENTER** / **CHECK** 键确认
通道 LED 右侧的 CH1 和 CH2 LED 变亮
4. 按 **ESC** / **DISP** 键退出设置菜单并返回正常操作。当开启追踪功能, MENU LED 显示“Ab”

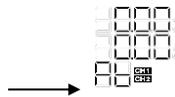

例如: 开启追踪功能

主-从功能

菜单项: 10

主-从功能用于 PSB 系列的并联或串联(仅 PSB-L)操作。最多串联 2 台 PSB-L; 最多并联 4 台(PSB-L)或 2 台(PSB-H)。注: 串联操作必须使用同型号的 PSB-L。

串联中的从属机在输出开启时, 仅显示输出电压。

从属机不用面板操作。仅 Off Timer、序列和外部控制功能设置需要在从属机上初始化。

并联中的从属机显示“---”。监测值显示在主机上。



注意

主-从操作不能使用 Hi-Ω 功能

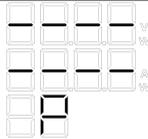

显示并联中的从属机

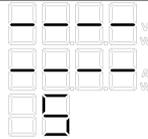

显示串联中的从属机

步骤

1. 开机的同时按住 **MENU** 键进行主-从设置
2. 用旋钮选择操作模式, 按 **ENTER** / **CHECK** 键确认。默认主-从设置关闭

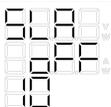

初始设置:

单台操作或串联中的主机

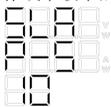

并联中的从属机

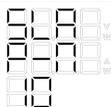

并联中的主机

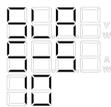

串联中的从属机(仅 PSB-L)

3. 若机子为并联主机，用旋钮设置总功率

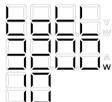

例如: 总功率 3200 W

4. 按 **ESC** / **DISP** 键退出设置并返回正常操作

电压传感

描述 PSB-2000 系列电源提供输出电压远程传感功能。该功能消除了电源和负载之间由于接触电阻或负载导线电阻导致的压降影响。
电压传感在一端最多补偿 1V 电压。



注意

使用电压传感功能时，电源前后端的电压一定不能超过额定电压。

若负载线很长，负载线中的电感和电容可能会引发振荡。为避免振荡，将几百至几千 μF 的电解电容连接到负载端。

步骤

1. 接线前关闭 POWER 开关
2. 断开后面板输出端左侧四端接线盒上短路在+和+S 端或 - 和 -S 端的线(PSB-2400L2 两个通道都需要如此操作)
3. 将正传感端(+S)与负载正极相连，负传感端(-S)与负载负端相连，如下显示。如果断开负载线，控制会不稳定，高于设置电压的电压值将用于负载。传感线一定要牢固连接。



注意

在额定输出电压时，约 1mA 电流流经传感线。使用 AWG 26~18 线作为传感线。

Fig. 远程传感连接
(PSB-L)

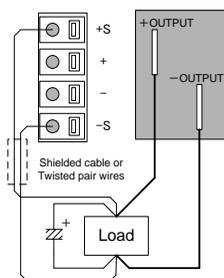
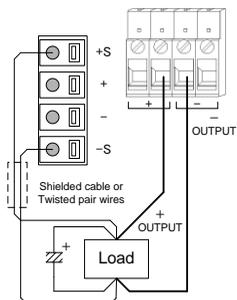

Fig. 远程传感连接
(PSB-H)



外部控制功能

描述	如下接口用于外部控制。
步骤	<ol style="list-style-type: none">1. XG5M-2635-N (OMRON 制造) (适合所有 PSB-2000 系列) <p>本章节介绍如何安装外部控制接口。</p>

安装 XG5M-2635-N 接口

- | | |
|----|--|
| 步骤 | <ol style="list-style-type: none">1. Remove the contacts from the housing.
Each contact can be easily removed by pulling it out while using a pin to hold down its catch. The contacts can also be removed using the XY2E-0001 removal tool (manufactured by OMRON Corporation).2. After connecting a wire to each contact, insert the contacts into the connector.
When inserting the contacts into the connector, ensure that the catch of each contact is firmly latched to the connector.
When connecting a wire to each contact, use the XY2B-7006 crimping tool (manufactured by OMRON Corporation).
Applicable wire:
Twisted wire AWG28 or 26
Outer diameter ϕ1.1 to 1.3 mm3. Mount semi-covers on both sides of the connector. |
|----|--|

Fig. Assembling
the External
Control
Connector
(XG5M-2635-N)

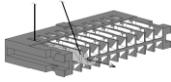

The 26-pin connector for external control: XG5M-2635-N (OMRON Corporation) Each contact can be easily removed by pulling it out while using a pin to hold down its catch.



The XY2E-0001 contact removal tool (manufactured by OMRON Corporation), can also be used to remove the contacts.

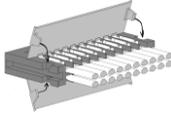

Applicable wire:
Twisted wire AWG28 or 26
Outer diameter $\phi 1.1$ to 1.3 mm



Mount the semi-covers on both sides of the connector. Here is a view of the completed assembly (20 pins shown)

输出电压监控和输出电流监控

介绍

使用 J3 外部控制接口可以监控 PSB-2000 系列电源的输出电压和输出电流。本章节介绍如何监控双通道机型(PSB-2400L2)的输出电压和输出电流。单通道机型操作同 CH 1。



注意

电压和电流监控电路的内阻约 $1k\Omega$ 。

注：通过监控电路的电流不要超过 $1mA$

步骤

1. 电压监控
CH1: Pin 17 和 16 (COM), CH2: Pin 8 和 7 (COM)
2. 电流监控
CH1: Pin 18 和 16 (COM), CH2: Pin 9 和 7 (COM)

Fig. 监控输出引脚

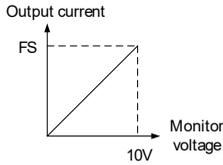
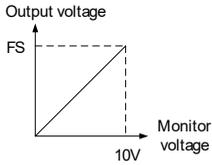
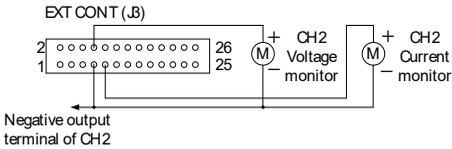
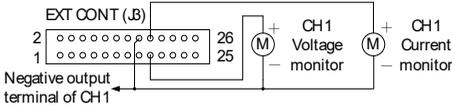

外部电压/电阻控制定电压(CV)

介绍 若选择外部控制，通过 J3 外部连接(EXT CONT)，外部电压或电阻可以控制输出电压。



注意

外部电压的负极与电源的负输出端相连。外部电压源浮动避免了事故或故障。
当操作在外部控制模式时，若外部电阻断开，会导致输出一个极高的电压。当断开电阻发生开路，电阻就相当于 10kΩ。如果电阻控制被使用时，为避免开路请使用短路开关来切换设定电阻。

引脚用以外部电压控制或外部电阻控制是相同的。在连接引脚之前，请检查控制模式选择 (外部电压或外部电阻)。

用于电压控制的外部电阻和外部电压控制管脚:

CH1: Pin 14 和 16 (COM)

CH2: Pin 5 和 7 (COM)

Fig. 外部电压/电阻控制端(CV)

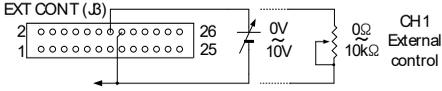

Negative output terminal of CH1

※ Use a shielded cable or twisted pair wires for this control.

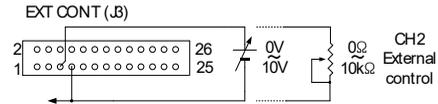

Negative output terminal of CH2

※ Use a shielded cable or twisted pair wires for this control.

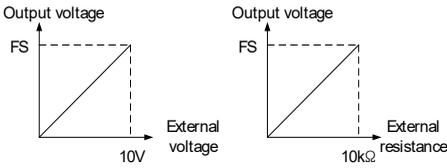

外部电压/电阻控制定电流(CC)

介绍 若选择外部控制，通过后面板 J3 接口(EXT CONT)，外部电压或外部电阻可以控制电流输出。

用于电流控制的外部电阻和外部电压控制管脚:

CH1: Pin 15 和 16 (COM)

CH2: Pin 6 和 7 (COM)

Fig. 外部电压/电阻控制引脚(CC)

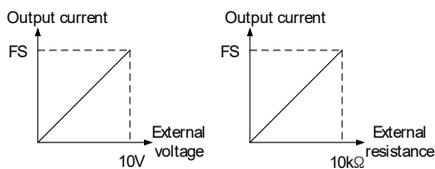
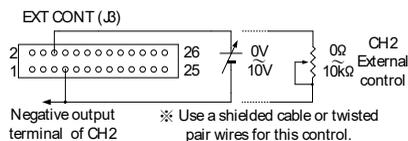
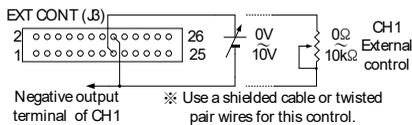

Output ON/OFF

介绍 若选择外部控制功能，使用外部接触开关可以开启或关闭输出。

用于 Output ON/OFF 控制的外部控制管脚:

CH1: Pins 21 和 22 (COM)

CH2: Pins 12 和 13 (COM)

短路: OUTPUT ON

开路: OUTPUT OFF

Fig. Output ON/OFF 管脚

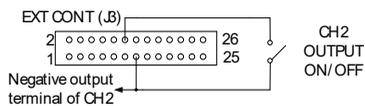
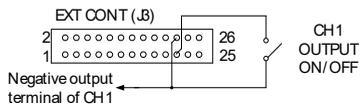

报警功能

介绍 外部接触开关可以使 PSB-L 进入报警状态。当处于报警状态时，输出关闭且 LED 显示“HARD”。拔掉电源或关机取消该状态。

外部控制管脚开启报警状态:

CH1: Pins 20 和 22 (COM)
CH2: Pins 11 和 13 (COM)

Fig. 外部报警输入引脚

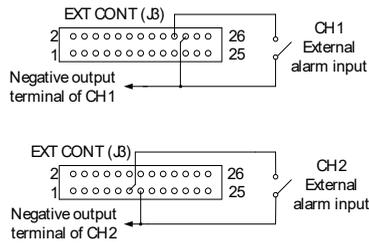

状态信号(CV, CC & ALARM)

介绍

- 定电压(CV)状态信号

当 PSB-2000 系列电源进入定电压(CV)状态时, 该状态信号呈低电平

- 定电流(CC)状态信号

当 PSB-2000 系列电源进入定电流(CC)状态时, 该状态信号呈低电平

- 报警状态信号

当 PSB-2000 系列电源进入报警状态时, 该状态信号呈低电平

状态信号特性 (SHARP PC3H7 光电耦合器)				
	项	符号	最大额定值	单位
输出	集电极-发射极电压	V_{CEO}	66	V
	发射极-集电极电压	V_{ECO}	6	V
	集电极电流	I_C	50	mA
	集电极损耗	P_C	150	mW
	总允许损耗	P_T	170	mW
	隔离电压	BV_S	2500	Vrms
CH1: 定电压(CV)状态: Pin 23 和 26 (COM)				
定电流(CC)状态: Pin 24 和 26 (COM)				
报警状态: Pin 25 和 26 (COM)				
CH2: 定电压(CV)状态: Pin 4 和 1 (COM)				
定电流(CC)状态: Pin 3 和 1 (COM)				
报警状态: Pin 2 和 1 (COM)				

Fig. 状态引脚

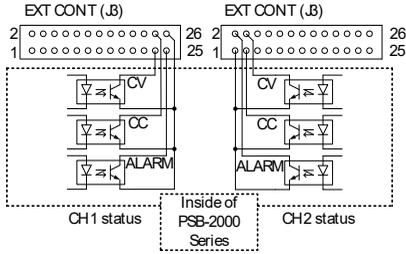
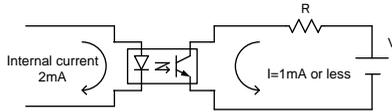

Fig. 光电耦合器
电流



※ Select and use proper voltage or resistance so that the open collector current does not exceed 1mA.

使用序列功能

描述 “序列功能”章节(见 57 页)介绍了在选配接口板后如何在电源上执行一个序列程序。
PSB_Sequence_203 软件可创建一个程序。详情见 57 页序列功能章节。PSB_Sequence_203 软件从 GW Instek 官网下载。

- 步骤**
1. 通过接口板编写一个序列程序。见 57 页
 2. 开启序列功能，见 57 页序列功能菜单
 3. 用 **PRESET** 键执行序列操作
每个 **PRESET** 键具有两种功能。**PRESET** 键与 **OUTPUT** 键在序列模式和正常操作模式时的功能不同。

在序列模式下，每个 Preset 键和 OUTPUT 键的功能描述如下：

Normal Mode	Sequence Mode
PRESET 1	Starts or pauses the sequence program. (▶/⏸)
PRESET 2	Skips to the previous step number. (◀◀) (when paused)
PRESET3	Skips to the next step number in the sequence. (▶▶) (when paused)
OUTPUT	Ends the sequence operation.



注意

OUTPUT 键不能开启序列操作。
使用 **PRESET 1** (▶/⏸) 键开始序列操作。即使序列功能开启且“• SEQUENCE LED”变亮，除非按 **PRESET 1** (▶/⏸) 键，否则仍然不能开始序列操作。即使当“•

SEQUENCE LED”变亮，除预设功能外，其它功能将正常工作。

如果在运行序列时按下 **OUTPUT** 键，序列操作完成。注意，在正常操作模式下，结束一个序列操作与关闭输出不同。

4. 在序列操作时的显示与正常操作不同，如下显示。当在序列操作时按下 **ESC / DISP** 键，步骤数显示在电压 LED，循环数显示在电流 LED。再按 **ESC / DISP** 键确认返回之前的显示

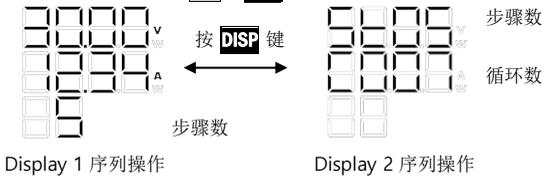

5. 序列操作时，在 **PRESET** 键下方的“• SEQUENCE LED”闪烁，表明序列操作正在执行。若需中途停止序列操作，按 **OUTPUT** 键或取消序列功能，见“序列功能”(57 页)

其它功能

显示报警状态

描述 当 PSB-2000 系列进入报警状态或使用外部控制接口 (见 77 页) 手动设置报警状态时, 屏幕显示报警标识。报警标识提示报警类型。发生报警时, 电源关闭输出并保持在报警状态。当开启保护功能 (除 OVP 和 OCP 外, 见 50 页), 所有操作 (面板操作等) 关闭, 电源停止工作。

按 **ESC** / **DISP** 键 1s 重设 OVP 或 OCP 报警 (见 50 页)。重新插入 AC 输入电源或开机, 可重设保护功能。

(1) OVP 报警 如果输出电压超过预设 OVP 值, 屏幕显示报警标识。

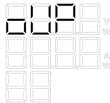

(2) OCP 报警 如果输出电流超过预设 OCP 值, 屏幕显示报警标识。

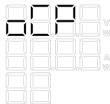

- (3) OHP 报警 如果内部检测点的温度超过设置温度时，屏幕显示 OHP 报警。各型号显示的 OHP 报警不同，如下图

所示。

例如，2400L2 各通道的 OHP 报警

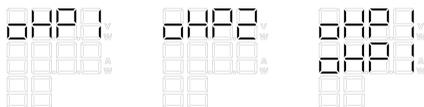

(2400L, 2400H) (2800L, 2800H) (2400L2)
2800L, 2800H)

- (4) HARD 报警 满足如下条件时，屏幕显示 HARD 报警：

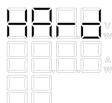

原因	描述
过电压(OVP)	如果电压超过额定输出电压的 110%，输出关闭
过电流(OCP)	如果电流超过额定输出电流的 110%，输出关闭
使用外部接口报警	当外部控制接口上的外部报警输出管脚短路时，引发报警。详情见 77 页，仅限 PSB-L

机框连接控制并联操作(除 PSB-2400L2)

描述 连接 PSB 系列电源，含主机最多可以并联控制 4 台 (PSB-L)，或 2 台 (PSB-H)。在进行并联操作前，主机和从属机必须正确设置，见 66 页主机-从属机功能章节。

使用选配的并联信号线 PSB-005 连接主机和从属机，也可以使用水平安装并联套件 PSB-003 或垂直安装并联套件。PSB-007 包含 PSB-003 和 PSB-004。

主机电流与从属机电流之和显示在主机上。见 152 页显示项和并联设置分辨率的规格值。

输出与主机有关。当按下主机的 OUTPUT 键时，从属机的输出也自动开启。



注意

PSB-2400L2 不能并联操作。



注意

错误接线或设置可能导致故障。在开启机框控制操作前重新检查设置。

如果从属机的负载线断开，过多电压立即流入从属机并触发“HArD”报警。请检查接线是否正确。主机显示总电流。如果实际值与设置电流和/或输出电流明显不同，可能是由于不正确的设置导致的，见 66 页主机-从属机功能章节。

当使用机框连接进行并联操作时，由于负载线电阻的影响，主机所显示的电流值可能会波动。在这种情况下，使用选配连接套件 PSB-003 (水平安装连接套件)、PSB-004 (垂直安装连接套件)或低阻负载线。

当使用机框连接控制 PSB-2400L 和 PSB-2800L 时，将 PSB-2400L 作为主机。

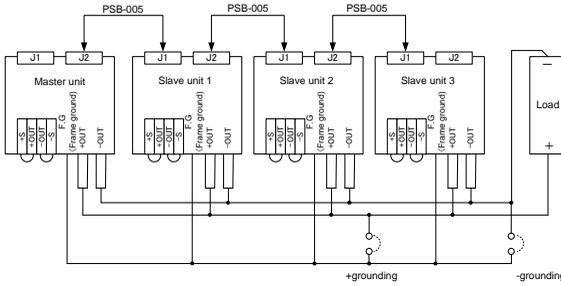

机框连接控制串联操作(除 PSB-2400L2, PSB-H 系列)

描述

PSB-L 系列(除 PSB-2400L2 外)含主机最多可以串联控制 2 台。在主机进行串联操作前，从属机必须正确设置，见 66 页主机-从属机功能章节。

输出与主机有关。当按下主机的 OUTPUT 键时，从属机的输出也自动开启。使用选配 PSB-006 线连接主机和从属机。



注意

错误接线或设置可能导致故障。

在开启机框控制操作前重新检查设置。

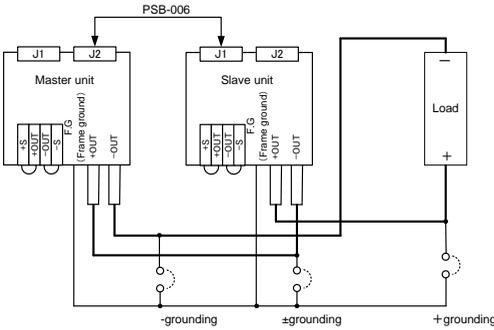

使用 PSB-2800LS 扩大功率(仅并联)

描述 并联 PSB-2800LS (加载机)可增大功率。以 PSB-2800L 作为主机进行并联时，可将输出功率最大增至 3200W。



注意

PSB-2800LS 不能串联操作。

Fig. PSB-2800LS 的前后面板

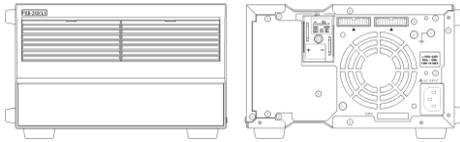

如何使用 PSB-2800LS

描述 PSB-2800LS 没有电源开关。当 PSB-2800LS 并联时，它与主机同步开启(详情见 66 页)。

换句话说，PSB-2800LS 不能单独使用。所以在使用 PSB-2800LS 前，请检查 AC 电源线、信号线和负载线是否连接正确。错误接线或设置会出现问题。

Fig. 水平连接

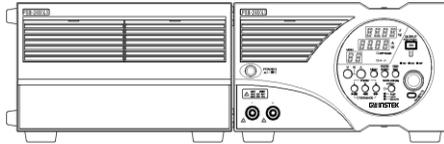
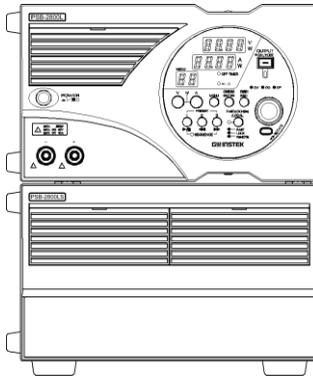

Fig. 垂直连接



使用 PSB-007 连接套件

描述 PSB-007 套件用于水平或垂直连接主机与从属机。



PSB-2800LS 不可串联操作。

如何垂直连接仪器

- 步骤
1. 移除 A 的底部支脚(请勿丢失)
 2. 用连接套件中提供的沉头螺丝将套件(PSB-007)固定在 B 的顶部(4 个位置)
 3. 将仪器按照下图所示位置放置, 使 B 上 PSB-007 的尖头可以插入 A 的小洞(移除支脚后显露出来)
 4. 滑动 A, 将后面板固定在连接套件(PSB-007)的支架上, 用垫圈拧紧(2 个位置)

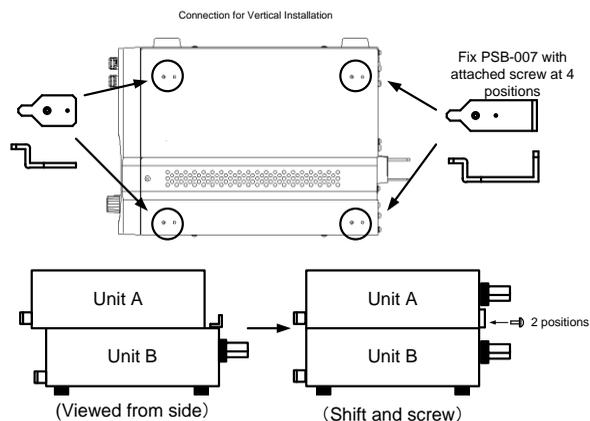

如何水平连接仪器

- 步骤
1. 移除 B 的侧面支脚(请勿丢失)
 2. 用连接套件中提供的沉头螺丝将套件(PSB-007)固定在 A 的侧面(4 个位置)
 3. 将仪器按照下图所示位置放置, 使 A 上 PSB-007 的尖头可以插入 B 的小洞(移除支脚后显露出来)
 4. 滑动 B, 将后面板固定在连接套件(PSB-004)的支架上, 用垫圈拧紧(2 个位置)

Connection for Horizontal Installation

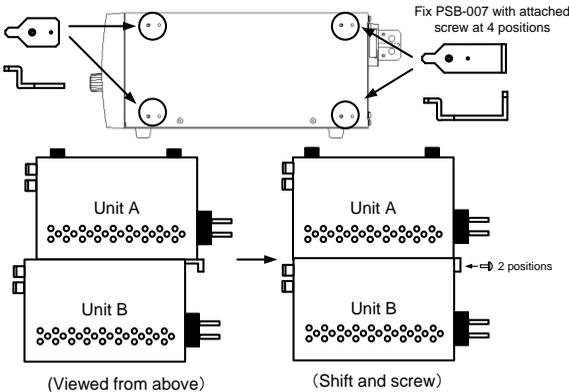

汇流排连接

Fig. 汇流排连接，以固定输出端子

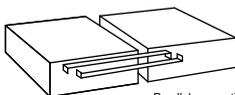

Parallel connection kit for Horizontal installation PSB-003

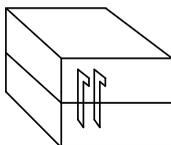

Parallel connection kit for vertical installation PSB-004

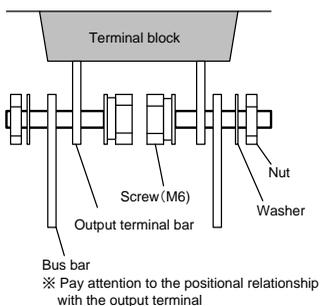

外部控制

远程控制

描述 安装选配的接口板后，PSB-2000 系列电源可以由 PC 或程序装置控制。两类接口板可选：PSB-001 (GPIB)和 PSB-002 (RS-232C 和 USB)。本地总线连接最多可以将 10 台连接在一起，其中 1 台作为主机。然后将主机通过 GPIB、RS-232C 或 USB 与 PC 相连。任何与其相连的设备均被视为从属装置控制。



注意

在本章节，术语“主机”和“从属机”与功率扩大章节 (83 页)用法一致，但在本文中含义不同。请勿混淆。

PSB-2800LS 不可安装选配接口板。



注意

接口板需返厂安装。安装或移除接口板，请参考接口板的安装说明书。出于安全考虑，在安装前请关闭电源。

接口连接

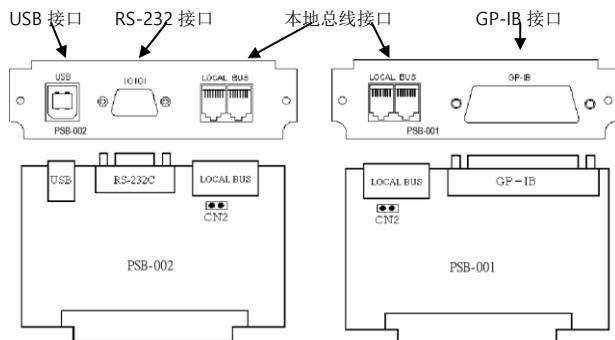

Fig. 接口示意图

PSB-001 规格(选配)

GPIB	
Specifications	Conforms to IEEE488-1978.
Interface functions	SH1, AH1, T6, L4, SR1, RL1, PR0, DC1, DT0, C0, & E1
Address setting	1 to 30
Delimiter	LF, EOI, & LF + EOI
Listener function	Output conditions of controlled power supply units may be set.
Talker function	Output conditions and setting conditions of controlled power supply units may be detected.
Service request function	Occurrence of alarms and errors and presence or absence of responses are reported.
Q'ty of connectable units	Maximum of 14 units are connectable with a single GP-IB card.

Local bus	
Specifications	Conforms to RS-485 Standards. Proprietary protocol.
Max. cable length	10 [m]
Connector type	RJ-11 (6-pin modular) Pin 2 (D+), pin 3 (D-)
Applicable cable	Modular cable: GRJ-1101 (500mm 6P6C RJ11)
Q'ty of connectable units	A maximum of 10 units can be connected in a daisy chain configuration.
Terminator	The terminator is built-in. It may be turned on or off with a jumper pin.
Q'ty of ports	2 ports, non-directional

PSB-002 规格(标配)

RS-232C	
Specifications	Conforms to the RS-232C Standards.
Data transmission speed	57600[bps]
Data bit	Data: 8 [bits], stop bit: 1 [bit], parity: none
Max. cable length	10[m]
Connector type	D-sub, 9-pin, plug
Applicable cable	Mass-marketed interlink cable (Socket 9-pin to socket 9-pin)
Q'ty of connectable units	One-to-one connection only

USB	
Specifications	Conforms to the USB Standards, Revision .2.0. Full speed: 12 [Mbps]
Connector type	USB series B
Device class	USB CDC/ACM Class.
Vendor code	2184
Product code	0031
Power supply	Self-powered only
Q'ty of connectable units	Maximum of 127 units are connectable through USB hubs.

Local bus	
Specifications	Conforms to the RS-485 Standards. Proprietary protocol.
Max. cable length	10 [m]
Connector type	RJ-11 (6-pin modular) Pin 2 (D+), pin 3 (D-)
Applicable cable	Modular cable: GRJ-1101 (500mm 6P6C RJ11)
Q'ty of connectable units	Maximum of 10 units are connectable through daisy chain connection.
Terminator	Built-in. May be turned on/off with jumper pin.
Q'ty of ports	2 ports, non-directional



PSB-001 和 PSB-002 接口板具有相同的本地总线接口，可连接从属机

连接方式

描述 通过本地总线连接多台 PSB-2000 系列电源，如下图所示：

Fig. 本地总线连接

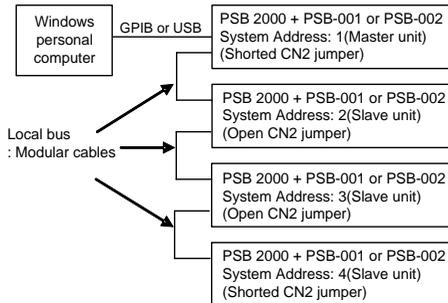

使用本地总线连接仪器时，接口板上任意一个本地总线接口均能作为输入或输出。

尽可能使用最短的模组线相互连接。终端 从头到尾 连城一个单元。用 CN2 跳线 PIN 将接口板短路连接。从所有的接口板 断开短路连接器。Using the example figure above, “Local Bus Connection”, CN2 跳线在系统地址 2 和 3 需要移除。接头板在出厂前是短路的。在保持断开连接请 不要丢弃它们。

连接线

步骤

- 使用专用的模块线，用于本地总线连接(GRJ-1101).
- 使用标准 GPIB 线，用于 GPIB 连接
- 使用 USB 线(适合全速 USB 或更高)，用于 USB 连接
- 使用互连线，用于 RS-232C 连接
管脚分配如下所示。注：正常交叉线不可使用

Fig. RS-232C 线
连接

		PC			PSB-002	
D-Sub 9 pin socket	2	RxD	<-->	3	D-Sub 9 pin socket	
	3	TxD	<-->	2		
	4	DTR	<-->	6		
	5	GND	<-->	5		
	6	DSR	<-->	4		
	7	RTS	<-->	8		
	8	CTS	<-->	7		
	FG		<-->	FG		

地址设置

描述 接口具备两个地址：PC 地址和系统地址。使用的地址类型与该仪器是连接到 PC 的主机还是连接到本地总线上的从属机有关。如果系统地址设为 1，那么该仪器被指定为主机。然后分配 PC 地址给主机。当与主机相连时，每个从属机都应该分配一个系统地址。



注意

与 PC 直接相连的系统地址一定是 1。

如果与主机相连的几个从属机具有同样的系统地址，系统将停止工作。

请勿给多个从属机分配相同的地址。

地址	范围	备注
系统地址	1~30	Address 1 用于主机。 其它地址用于从属机。与主机相连的从属机一定要有不同系统地址。
PC 地址(GPIB 地址)	1~30	仅当系统地址设为 1 时，可以设置 PC 地址。 对于选配的 GPIB 接口，它是 GPIB 地址。对于 RS232 和 USB 接口，不使用 PC 地址。

步骤

1. 开机的同时按 **▲** 键设置系统地址和/或 PC 地址。首先显示型号名称和版本数据，然后显示接口类型。此后，可以设置系统地址 ¹。
“Sy.Ad”显示在电压 LED，地址显示在电流 LED。旋转旋钮选择系统地址，按 **ENTER** / **CHECK** 键确认

如果仪器所设的系统地址非 1，那么将返回正常操作。

¹ 按 **▲** 键直至显示“Sy.Ad”

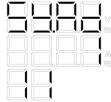

系统地址 1

- 2. 如果系统地址设为 1, “PC.Ad”显示在电压 LED, 表明可以设置 PC 地址。旋转旋钮选择 PC 地址, 按 **ENTER** / **CHECK** 键确认

仪器将返回正常操作

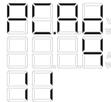

PC 地址 4

- 3. 将系统地址和 PC 地址保存在非易失性的存储器中。即使关闭电源, 仍然保存系统地址和 PC 地址

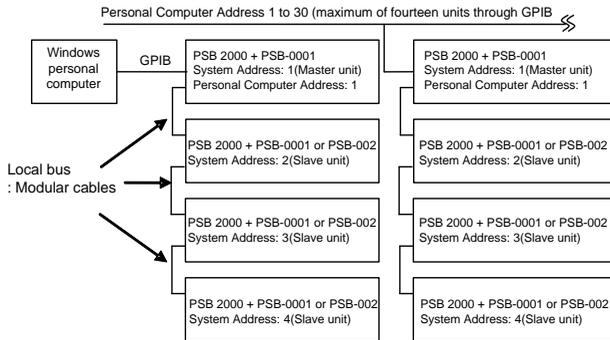



若需要 USB 接口时，在主机上插入 PSB-002 接口板

使用接口

使用 GPIB 接口

描述

- All GPIB operations have been tested using a NATIONAL INSTRUMENTS GPIB controller and sample programs. All interface cards conforming to the IEEE488 standard should be compatible with the PSB-001 interface board. However, compatibility cannot be assured.
 - The PSB-001 accepts the following delimiters: LF (0×0A), EOI, and LF (0×0A) + EOI. It sends a response using LF (0×0A) + EOI only.
 - When using the local bus through GPIB, control must be returned to the master unit after transferring commands to the slave units ². Unless control has been returned to the master unit, the GPIB controller on the PC may fail to recognize the interface board properly.
 - The Personal Computer Address may be set only when the System Address is set to 1. The Personal Computer Address is used to represent the GPIB address.
- ² Send ADDR1.

註解 [U2]: Added this note

使用 USB 接口

描述

- You may use the USB port of your Personal computer for communication through the USB interface. Microsoft Windows 98SE, 2000, XP to Windows 8* may be used.
- To use the USB interface, it is necessary to install the device driver.
- This driver may fail to work properly if the host PC is in the suspend mode or sleep mode. The driver may not run at its full performance if the screen saver or another application is running.



注意

USB hubs are easily affected by external noise, which may cause errors. When using USB hubs try to self-powered hubs so that the connection is not affected by noise.

Windows 8 系统 安装 USB 驱动

*To install the USB driver in Windows 8, you must first disable "Device driver signature enforcement".

Use the following steps to disable device driver signature enforcement:

Go to the Charms bar → Click on Settings → Click on Power → Hold the SHIFT key and click Restart → Click Troubleshoot → Advanced Options → Startup Settings → Restart → Select 7) Disable driver signature enforcement. → The PC will now restart.

After the PC restarts, it will now be possible to install the USB driver on Windows 8.

使用 RS-232C 接口

描述

- The serial port on a PC or sequencer can be used for communication through the RS232C interface. The interface uses CTS-RTS for flow control. Please note that with this type of communication, if the flow control fails to work properly, some characters may be lost, which may result in a malfunction or error.

使用局部总线

描述

- The communication timeout time between the PC and master unit should be longer when the local bus is used. The communication time is influenced by the cable length. Check it and determine the time-out value.
- Remember that when connecting units together using the local bus connection, any of the local bus ports on the interface board can be used as the input or output.



注意

A General Description About Communication

When you are going to control several PSB 2000 Series power supply units from a PC, the electrical potential of the frame of the power supply units must be equal to that of the PC frame. If those potentials are different, you may receive electric shocks or the PC may get damaged.

註解 [U3]: Added the note here.

通信接口

描述

- Every communication command consists of general alphanumeric characters and symbols and a header, which is the abbreviation of a function. Parameters can be either an integer (NR1) or a floating point number with decimal places (NR2). Parameters following the tenth character are ignored. Decimal places are rounded off according to the actual setting resolution. Responses contain no header. Only parameters are sent as responses.
- LF (0x0A) is used as the delimiter, which indicates the end_of_data. Multiple commands consisting of several continuous commands are not applicable to the PSB 2000 Series power supply units. Thus, commands must be separated with delimiters. If delimiters are used, the interface unit automatically controls the flow of communication. Commands and queries are accepted whether they are written in capital letters or lowercase letters.
- Use the address command “:ADDR” to specify a System Address of a slave unit when communicating with a slave unit on the local bus from the PC. Since address 1 has been set by default, the System Address of the master unit is to be specified.
- Commands that are only applicable to the dual channel model (PSB-2400L2) will cause an error if they are used with a single channel model. If a command is to be used for either channel, “:A” or “:B” should be added to the command to specify which channel the command applies to. (:A

represents CH1, :B represents CH2)

- An error occurs if a command causing a conflicting operation is sent while the sequence, tracking or external control function is working.

指令列表

Category	Set item	Command	Query	Page	Function
Output Setting	Output voltage setting	:VOLT	:VOLT?	42	106
	OVP setting	:VOLT:PROT	:VOLT:PROT?	50	107
	Output current setting	:CURR	:CURR?	43	108
	OCP setting	:CURR:PROT	:CURR:PROT?	50	109
	Output power setting	:POW	:POW?	43	109
	Output ON/OFF	:OUTP	:OUTP?	44	110
Function	Hi-Ω ON/OFF	:CONF:HIZ	:CONF:HIZ?	53	111
	Hi-Ω time setting	:CONF:HIZ:HOLD	:CONF:HIZ:HOLD?	53	111
	Display switch	:CONF:DISP	:CONF:DISP?	42	112
	Tracking ON/OFF	:CONF:TRAC	:CONF:TRAC?	65	113
External control	External control setting	:EXT:MOD	:EXT:MOD?	59	114
	External voltage control	:EXT:VOLT	:EXT:VOLT?	59	114
	External current control	:EXT:CURR	:EXT:CURR?	59	116
	Output switching	:EXT:OUTP	:EXT:OUTP?	61	116
Off timer	Off timer ON/OFF	:TIMER:MOD	:TIMER:MOD?	55	117
	Off timer value setting	:TIMER:SET	:TIMER:SET?	55	117
Delay	Delay ON/OFF	:DELAY:MOD	:DELAY:MOD?	63	119
	Rise delay time	:DELAY:RISE	:DELAY:RISE?	63	119
	Fall delay time	:DELAY:FALL	:DELAY:FALL?	63	120

Status check	Monitor request	-----	:MEAS?	71	120
Preset	Call	:PRES:CALL	:PRES:CALL?	50	121
	Save	:PRES:SAVE	:PRES:SAVE?	50	121
Sequence	Sequence mode setting	:SEQ:MOD	:SEQ:MOD?	57	122
	Jump	:SEQ:STEP	:SEQ:STEP?	57, 80	122
	Start step	:SEQ:START	:SEQ:START?	57, 80	123
	End step	:SEQ:END	:SEQ:END?	57, 80	123
	Repetition frequency	:SEQ:CYCL	:SEQ:CYCL?	57, 80	123
	Data transfer	:SEQ:DOWNLOAD	:SEQ:DOWNLOAD?	---	124
Common	Model inquiry	-	*IDN?	---	124
	ESR query	-	*ESR?	---	125
	Event enable	*ESE	*ESE?	---	125
	STB query	-	*STB?	---	125
	SRQ enable	*SRE	*SRE?	---	125
	Clear	*CLS	-	---	125
	Reset	*RST	-	---	126
	Completion	*OPC	*OPC?	---	126
Extension	Wait for completion	*WAI	-	---	126
	Local communication	:ADDR	-	98	127
	Remote mode	:REMOTE	:REMOTE?	47	128

输出电压设置(:VOLT)

该指令用于设置或查询输出电压。

Setting	:VOLT <value> Sets the output voltage of a single channel model. :VOLT:A <value>
---------	--

	<p>Sets the output voltage of CH1. :VOLT:B <value> Sets the output voltage of CH2. The <value> range is from 0.00 to 82.00 (PSB-L), 0.0 to 820.0 (PSB-H). Two decimal places are valid.</p>
Application example	<p>:VOLT 10.10 Sets the output voltage of a single channel model to 10.10V.</p>
Query	<p>:VOLT? Inquires about the set output voltage of a single channel model. :VOLT:A? Inquires about the set output voltage of CH1. :VOLT:B? Inquires about the set output voltage of CH2.</p>
Response example	<p>10.10 Indicates that the set output voltage is 10.10V.</p>
Remark	<p>When the tracking mode is on, setting CH1 will affect CH2. Setting CH2 in the tracking mode will cause an execution error.</p>

OVP 设置(:VOLT:PROT)

该指令用于设置或查询 OVP (过电压保护)值。

Setting	<p>:VOLT:PROT <value> Sets the OVP value of a single channel model. :VOLT:PROT:A <value> Sets the OVP value of CH1. :VOLT:PROT:B <value> Sets the OVP value of CH2. The <value> range is from 1.00 to 84.00(PSB-L), 10.0 to 840.0(PSB-H). Two decimal places are valid.</p>
Application example	<p>:VOLT: PROT 10.10 Sets the OVP value of a single channel model to 10.10V.</p>
Query	<p>:VOLT:PROT? Inquires about the set OVP value of a single channel model. :VOLT:PROT:A? Inquires about the set OVP value of CH1. :VOLT:PROT:B? Inquires about the set OVP value of CH2.</p>

Response example	10.10 Indicates that the set OVP value is 10.10V.
Remark	None

输出电流设置(:CURR)

该指令用于设置或查询输出电流。

Setting	:CURR <value> Sets the output current of a single channel model. :CURR:A <value> Sets the output current of CH1. :CURR:B <value> Sets the output current of CH2. The <value> range for single-unit operation is as shown below: PSB-2400L & PSB-2400L2: 0.00 to 41.00 PSB-2800L: 0.00 to 82.00 PSB-2400H: 0.00 to 3.07 PSB-2800H: 0.00 to 6.15 Two decimal places are valid. The setting range changes when the power supplies are used in parallel. Resolution in parallel operation: 100mA Setting range: 0.0 to (total current x 1.025)
Application example	:CURR 10.10 Sets the output current of a single channel model to 10.10A.
Query	:CURR? Inquires about the set output current of a single channel model. :CURR:A? Inquires about the set output current of CH1. :CURR:B? Inquires about the set output current of CH2.
Response example	10.10 Indicates that the set output current is 10.10A.
Remark	When the tracking mode is on, setting CH1 will affect CH2. Setting CH2 in the tracking mode will cause an execution error.

OCB 设置(:CURR:PROT)

该指令用于设置或查询 OCB (过电流保护)值。

Setting	<pre>:CURR:PROT <value></pre> <p>Sets the OCB value of a single channel model.</p> <pre>:CURR:PROT:A <value></pre> <p>Sets the OCB value of CH1.</p> <pre>:CURR:PROT:B <value></pre> <p>Sets the OCB value of CH2.</p> <p>The <value> range in single-unit operation is as shown below: PSB-2400L & PSB-2400L2: 1.00 to 42.00 PSB-2800L: 1.00 to 84.00 PSB-2400H: 0.10 to 3.15 PSB-2800H: 0.10 to 6.30 Two decimal places are valid. The setting range changes when the power supplies are used in parallel. Resolution in parallel operation: 100mA Setting range: 0.0 to (total current x 1.05)</p>
Application example	<pre>:CURR:PROT 10.10</pre> <p>Sets the OCB value of a single channel model to 10.10A.</p>
Query	<pre>:CURR:PROT?</pre> <p>Inquires about the set OCB value of a single channel model.</p> <pre>:CURR:PROT:A?</pre> <p>Inquires about the set OCB value of CH1.</p> <pre>:CURR:PROT:B?</pre> <p>Inquires about the set OCB value of CH2.</p>
Response example	<pre>10.10</pre> <p>Indicates that the set OCB value is 10.10A.</p>
Remark	<p>When the tracking mode is on, setting CH1 will affect CH2. Setting CH2 in the tracking mode will cause an execution error.</p>

输出功率设置(:POW)

该指令用于设置或查询输出功率。

Setting	<pre>:POW <value></pre> <p>Sets the output power of a single channel model.</p>
---------	---

	<p>:POW:A <value> Sets the output power of CH1. :POW:B <value> Sets the output power of CH2. The <value> range in single-unit operation is as shown below: PSB-2400L, PSB-2400L2, PSB-2400H: 10 to 410 PSB-2800L, PSB-2800H: 10 to 820 Integers are valid. The setting range changes when the power supplies are used in parallel. Setting range: 0.0 to (total power x 1.025)</p>
Application example	<p>:POW 100 Sets the output power of a single channel model to 100W.</p>
Query	<p>:POW? Inquires about the set output power of a single channel model. :POW:A? Inquires about the set output power of CH1. :POW:B? Inquires about the set output power of CH2.</p>
Response example	<p>100 Indicates that the set output power is 100W.</p>
Remark	<p>When the tracking mode is on, setting CH1 will affect CH2. Setting CH2 in the tracking mode will cause an execution error.</p>

输出 ON/OFF (:OUTP)

该指令用于开启或关闭输出。

Setting	<p>:OUTP <value> Sets the output of a single channel model. :OUTP:A <value> Sets the output of CH1. :OUTP:B <value> Sets the output of CH2. The relationship between <value> and On/Off is as shown below: 1: Output On, 0: Output Off On the dual channel model, :OUTP selects the OUTPUT. The output is activated only after <value> is set to 1.</p>
Application example	<p>:OUTP 1 Activates output.</p>

Query	:OUTP? Inquires about the output setting of a single channel model. :OUTP:A? Inquires about the output setting of CH1. :OUTP:B? Inquires about the output setting of CH2.
Response example	1 Indicates that the output is activated. The return values of the query have the same meaning as the setting <value>.
Remark	This command causes an execution error if the output is externally controlled. Sending the :OUTP command causes a command error when both channels of the dual channel model are deactivated.

Hi-Ω ON/OFF(:CONF:HIZ)

该功能用于开启或关闭 Hi-Ω 功能，仅适合 PSB-L 系列。

Setting	:CONF:HIZ <value> <value> is as shown below: 1: Hi-Ω On 0: Hi-Ω Off
Application example	:CONF:HIZ 1 Activates the Hi-Ω function.
Query	:CONF:HIZ? Inquires about the setting.
Response example	1 Indicates that the Hi-Ω function is working. The return values of the query have the same function as the setting <value>.
Remark	None

Hi-Ω 时间设置(:CONF:HIZ:HOLD)

该指令用于设置 Hi-Ω 功能保持时间(in minutes)，仅适合 PSB-L 系列。

Setting	:CONF:HIZ:HOLD <value>
---------	------------------------

	<value> is set in 5 steps between 5 and 30. Any value not ending with 0 or 5 is rounded off.
Application example	:CONF:HIZ:HOLD20 Sets the Hi-Ω holding time to 20 minutes.
Query	:CONF:HIZ:HOLD? Inquires about the setting.
Response example	5 Indicates that the Hi-Ω holding time is five minutes. The return values of the query have the same function as the setting <value>.
Remark	None

显示切换(:CONF:DISP)

该指令用于切换电压、电流和功率显示模式。

Setting	:CONF:DISP <value> <value> is as shown below: 1: CH1 voltage + current display 2: CH1 voltage + power display 3: CH1 power + current display 4: CH2 voltage + current display 5: CH2 voltage + power display 6: CH2 power + current display 7: Sequence or Off Timer display For a single channel model, use the values 1 to 3 or 7 to specify a display mode.
Application example	:CONF:DISP 1 Selects the voltage + current display mode.
Query	:CONF:DISP? Inquires about the display setting.
Response example	1 Indicates that the voltage + current display mode is selected. The return values of the query have the same meaning as the setting <value>.
Remark	A value between 4 and 6 causes an error if it is set for a single channel model (single channel models don't have CH2). The value of 7 causes an error unless the Off Timer or sequence function (Pause, RUN) is turned on.

追踪 ON/OFF (:CONF:TRAC)

该指令用于开启或关闭追踪功能。仅适合 PSB-2400L2。

Setting	:CONF:TRAC <value> <value> is as shown below: 0: Off 1: On
Application example	:CONF:TRAC 1 Activates the tracking function.
Query	:CONF:TRAC? Inquires about the setting status.
Response example	1 Indicates that the tracking function is working. The query return has the same meaning as the setting <value>.
Remark	This command causes an error if it is set for a single channel model or if a sequence operation is running.

外部控制设置(:EXT:MOD)

该指令用于设置外部控制模式。

Setting	:EXT:MOD <value> <value> is as shown below: 0: Settings are controlled from the front panel or via remote control. 1: External voltage control 2: External resistance control
Application example	:EXT:MOD 1 Selects the external voltage control.
Query	:EXT:MOD? Inquires about the setting status.
Response example	1 Indicates that external voltage control has been enabled. The query return has the same meaning as the setting <value>.
Remark	This command causes an error if a sequence operation is running.

外部控制电压输出 ON/OFF (:EXT:VOLT)

This command chooses whether the external control is used to control the output voltage or if the front panel controls are used to control the output voltage.

Setting	:EXT:VOLT <value> Activates or deactivates external control of the output voltage of a single channel model.
	:EXT:VOLT:A <value> Activates or deactivates external control of the output voltage of CH1. :EXT:VOLT:B <value> Activates or deactivates external control of the voltage output of CH2. <value> is as shown below: 0: Deactivates external control of the voltage output (Allows the voltage output to be controlled from the front panel or from remote control). 1: Activates external control of the voltage output.

Application example	:EXT:VOLT 1 Selects external control of the voltage output.
Query	:EXT:VOLT? Inquires about the setting.
Response example	1 Indicates that external control of the voltage output is enabled. The query return value has the same meaning as the setting <value>.
Remark	This command causes an error if the sequence function is running.

外部控制电流输出 ON/OFF (:EXT:CURR)

This command chooses whether the external control is used to control the output current or if the front panel controls are used to control the output current.

Setting	:EXT:CURR <value> Activates or deactivates external control of the output current of a single channel model. :EXT:CURR:A <value> Activates or deactivates external control of the output current of CH1. :EXT:CURR:B <value> Activates or deactivates external control of the output current of CH2. <value> is as shown below: 0: Deactivates external control of the output current (Allows the current output to be controlled with the front panel controls or via remote control). 1: Activates external control of the current output.
Application example	:EXT:CURR 1 Selects the external control of the current output.
Query	:EXT:CURR? Inquires about the setting.
Response example	1 Indicates that external control of the current output is enabled. The query return value has the same meaning as the setting <value>.
Remark	This command causes an error during sequence operation (RUN).

输出切换(:EXT:OUTP)

This command selects output On/Off with external contacts.

Setting	:EXT:OUTP <value> <value> is as shown below: 0: Control from the panel or through communication 1: Output On/Off with external contacts
Application	:EXT:OUTP 1

example	Selects output On/Off with external contacts.
Query	:EXT:OUTP? Inquires about the setting.
Response example	1 Indicates that output On/Off with external contacts is working. The query return value has the same meaning as the setting <value>.
Remark	This command causes an error if the sequence function is running.

Off Timer ON/OFF (:TIMER:MOD)

This command activates or deactivates the Off Timer.

Setting	:TIMER:MOD <value> <value> is as shown below: 0: Deactivates the Off Timer. 1: Activates the Off Timer.
Application example	:TIMER:MOD 1 Activates the Off Timer.
Query	:TIMER:MOD? Inquires about the setting.
Response example	1 Indicates that the Off Timer is activated. The query return value has the same meaning as the setting <value>.
Remark	This command causes an error if the sequence function is running.

Off Timer 值设置(:TIMER:SET)

This command sets or inquires what the value of the Off Timer setting is.

Setting	:TIMER:SET <value> The <value> range is between 0.1 and 99.5. Specify the hour in the integer part and the minutes in the first decimal place (in units of 10 minutes).
Application example	:TIMER:SET 10.3 Set the Off Timer value to 10 hours and 30 minutes.
Query	:TIMER:SET? Inquires about the setting.

Response example	15.2 Indicates that the Off Timer value is set to 15 hours and 20 minutes.
Remark	This command causes an error if the sequence function is running. It also causes an error if a value between 6 and 9 is set in the first decimal place (i.e, a value of greater than 60 minutes).

延迟功能 ON/OFF (:DELAY:MOD)

This command activates or deactivates the delay function. This function only applies to the PSB-2400L2.

Setting	:DELAY:MOD <value> <value> is as shown below: 0: Deactivates the delay function. (Normal) 1: Activates the delay function.
Application example	:DELAY:MOD 1 Activates the delay function.
Query	:DELAY:MOD? Inquires about the setting.
Response example	1 Indicates that the delay function is working. The query return value has the same meaning as the setting <value>.
Remark	This command causes an error if the sequence function is running.

延迟上升时间设置(:DELAY:RISE)

This command sets or inquires about the delay time for turning on the output. This function only applies to the PSB-2400L2.

Setting	:DELAY:RISE <value> The <value> range is from -9.99 to +10.00 seconds.
Application example	:DELAY:RISE 0.3 Sets the delay time for turning on the output to 0.3 seconds.
Query	:DELAY:RISE? Inquires about the setting.
Response example	0.3 Indicates that the delay time for turning on the output is set to 0.3 seconds.
Remark	This command causes an error if the sequence function is running.

延迟下降时间设置(:DELAY:FALL)

This command sets or inquires about the delay time for turning off output.

Setting	:DELAY:FALL <value> The <value> range is from -9.99 to +10.00 seconds.
Application example	:DELAY:FALL 0.3 Sets the delay time for turning off output to 0.3 second.
Query	:DELAY:FALL? Inquires about the setting.
Response example	0.3 Indicates that the delay time for turning off output is set to 0.3 seconds.
Remark	This command causes an error if the sequence function is running.

监控查询(:MEAS?)

This command inquires about the monitored data. In response, the voltage, current, power and CV/CC/CP status are returned, in that order.

Setting	None
Query	:MEAS? Inquires about the monitored data of the single channel model. :MEAS:A? Inquires about the monitored data of CH1. :MEAS:B? Inquires about the monitored data of CH2.
Response example	20.00,5.00,100,0 Indicates that the output values are 20.00V, 5.00A and 100W and the CV function is working. The voltage, current, power and status are returned in this order. The status of the protection functions are: 0 (CV), 1 (CC) or 2 (CP).
Remark	None

预设调取(:PRES:CALL)

This command recalls and inquires about preset data.

Setting	:PRES:CALL <value> <value> is as shown below: 0: Cancels preset. 1: Calls PRESET 1 data. 2: Calls PRESET 2 data. 3: Calls PRESET 3 data.
Application example	:PRES:CALL1 Recalls the set values stored in PRESET 1.
Query	:PRES:CALL? Inquires about the setting.
Response example	1 Indicates that PRESET 1 is selected. The query return value has the same meaning as the setting <value>.
Remark	This command causes an error if the sequence function is running.

预设保存(:PRES:SAVE)

This command saves the current set values (voltage, current and power) in PRESET memory.

Setting	:PRES:SAVE <value> <value> is as shown below: 1: Saves the current set value in PRESET 1. 2: Saves the current set value in PRESET 2. 3: Saves the current set value in PRESET 3.
Application example	:PRES:SAVE1 Saves the current set values in PRESET 1.
Query	None
Remark	This command causes an error if the sequence function is running.

序列模式设置(:SEQ:MOD)

This command controls a sequence operation. It can start, stop or pause a sequence.

Setting	:SEQ:MOD <value> <value> is as shown below: 0: Stops sequence operation. 1: Pause sequence operation – Waits for start. 2: Runs sequence operation (Executes sequence).
Application example	:SEQ:MOD 2 Runs the sequence.
Query	:SEQ:MOD? Inquires about the setting.
Response example	2 Indicates that sequence operation is being executed. This command causes an error if the sequence function is running.
Remark	None

序列跳跃设置(:SEQ:STEP)

This command jumps to a specified step in the sequence operation.

Setting	:SEQ:STEP <value> The <value> range is from 0 to 99. This command can only be executed when a sequence is paused.
Application example	:SEQ:STEP 2 Jumps to step 2.
Query	:SEQ:STEP? Inquires about the setting.
Response example	2,1 Indicates that step 2 is selected and the repetition frequency is 1(looped one time).
Remark	This command causes an error if the sequence function is running.

序列开始步骤设置(:SEQ:START)

This command specifies which step to start from when running a sequence.

Setting	:SEQ:START<value> The <value> range is from 0 to 99.
Application example	:SEQ:START2 Sets the sequence to start from step no. 2.
Query	:SEQ:START? Inquires about the setting.
Response example	2 Indicates that the sequence starts from step 2.
Remark	None

序列停止步骤设置(:SEQ:END)

This command specifies which step to end the sequence on.

Setting	:SEQ:END<value> The <value> range is from 0 to 99.
Application example	:SEQ:END2 Sets the sequence to end at step no. 2.
Query	:SEQ:END? Inquires about the setting.
Response example	2 Indicates that the sequence ends at step no. 2.
Remark	None

序列重复率设置(:SEQ:CYCL)

This command specifies the number of times the sequence is looped(repetition frequency).

Setting	:SEQ:YCL<value> The <value> range is from 0 to 999. When set to 0, the sequence is repeated endlessly (infinite loops).
Application	:SEQ:CYCL 2

example	Sets the sequence to loop 2 times.
Query	:SEQ:CYCL? Inquires about the setting.
Response example	2 Indicates that the sequence is looped twice.
Remark	None

序列数据传送(:SEQ:DOWNLOAD)

This command transfers the sequence set data.

Setting	:SEQ:DOWNLOAD<value> <value> represents 1609-byte binary sequence set data.
Application example	:SE:DOWNLOAD#6001600..... LF Transfers an 8-byte header for the binary data, 1600-bytes of actual data, and a 1 byte for the delimiter (total: 1609 bytes).
Query	:SEQ:DOWNLOAD? Requests the sequence data.
Response example	#6001600..... LF 1609-byte sequence set data are returned.
Remark	PSB_Sequence_203 software is available. Use it for setting ¹

¹ The application software for sequence operation may be downloaded from the GW Instek website.

型号查询(*IDN?)

This command returns the company name, model name, serial number and version number.

Setting	None. Query only.
Query	*IDN? The company name, model name, serial number and version are returned in this order.
Response example	GW Instek,PSB-2400L,0,1.00/1.00

标准事件状态寄存器查询(*ESR?)

The function of this command is described in the “Standard Event Status Register” in the following section.

标准事件状态使能寄存器设置(*ESE)

The function of this command is described in “Standard Event Status Enable register” in the following section.

状态字节查询(*STB?)

The function of this command is described in “Status Byte Register” in the following section.

SRQ (服务请求)寄存器设置(*SRE)

The function of this command is described in “Service Request Register” in the following section.

缓冲器清除(*CLS)

This command clears the buffers.

Setting	*CLS Clears the send buffer, receive buffer, local bus buffer, command execution buffer, status byte and event register.
Query	None

通信重设(*RST)

This command clears the communication status.

Setting	*RST Clears the send buffer, receive buffer, local bus buffer, command execution buffer, status byte and event register. Clears the ESE register and SRE register and also clears the talker and listener settings.
Query	None

指令完成(*OPC)

This command sets bit 0 of the standard event status register (ESR) when all current overlapped commands have been processed.

Setting	*OPC Sets bit 0 of the ESR when all current overlapped commands are complete. A SRQ is generated depending on the status of the ESE register and SRE register.
Query	*OPC? The value "1" is returned when all current commands are completed.

等待完成(*WAI)

本指令等待指令完成。

Setting	*WAI Prevents new commands/queries from being executed until all outstanding overlapped commands have completed.
Query	None

本地地址设置(:ADDR)

本指令指定本地总线上从属机的地址。

Setting	:ADDR <value> The <value> range is from 1 to 30. Specifies the address of a slave on the local bus to be controlled. This command causes no error even if an out-of-range System Address is specified.
Application example	:ADDR3 Sets the System Address of the power supply (slave) to 3. :ADDR1 Sets the System Address of the power supply to 1. A System Address of 1 means that the unit is also set as a master unit.
Query	None
Remark	The default setting is 1 (master unit). Reset <value> to 1 after completion of communication with the local bus.

远程/本地设置(:REMOTE)

关于远程/本地状态的指令设置或查询。

Setting	:REMOTE <value> <value> is as shown below: 0: Local status (Normal manual operation) 1: Remote status 2: Local lockout remote status (Cannot return to the local status through key operation.)
Application example	:REMOTE0 Sets the unit to local status.
Query	:REMOTE?
Response example	1 Indicates that the unit is in the remote status. The query return value has the same meaning as the setting <value>.
Remark	If this query is sent when the unit is in the local status, a response is made after the unit enters the remote status. Thus, 1 is returned.

寄存器

介绍

PSB 电源具有寄存器，符合 IEEE488.2 规定。

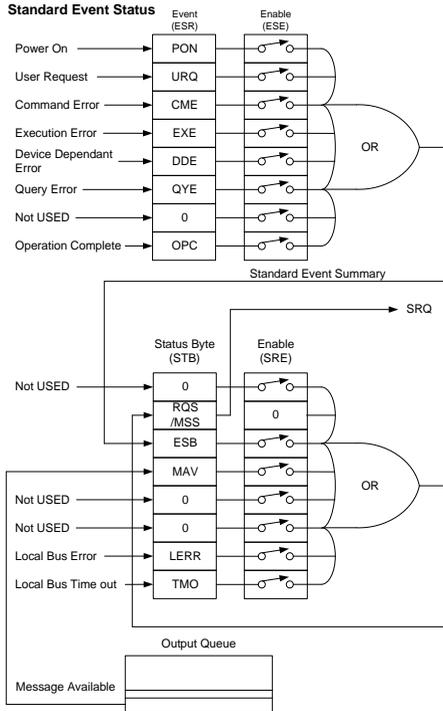

状态字节寄存器(STB, SRE)

Bit	Data	Item	Description	Initial STB value	Initial SRE value
7	128	0	Unused.	0	0
6	64	SRQ RQS MSS	Service request Message summary	0	0
5	32	ESB	Standard event summary	0	0
4	16	MAV	Output message available	0	0
3	8	0	Unused.	0	0
2	4	0	Unused.	0	0
1	2	LERR	Local bus error	0	0
0	1	TMO	Local bus Time out	0	0

总结 当设置为“0”，每位是屏蔽的。(0为默认设置)，当设置为“1” A bit 不在被屏蔽。不用的位均设为“0”。

Item	Description
SRQ RQS MSS	The MSS bit is the summary bit for the status byte register. The MSS bit is set to 1 when the Boolean AND of the bits in the status byte register and the bits in the service request enable register equals 1. The RQS bit is set to 1 when the MSS bit changes from 0 to 1. The RQS bit is cleared when the MSS bit is cleared or serial polling is used.
ESB	Indicates that an event occurs in the standard event status register.
MAV	Indicates that there is a message in the output queue.
*SRE?	Sets or inquires about the service request enable register.
Setting command	*SRE <value>

		The <value> range is from 0 to 255.
	Application example	*SRE 48 Enables the MAV and ESB bits since the value of 48 (→ 00110000 in binary) sets bit 4(MAV) and 5(ESB).
	Query command	*SRE?
	Response example	48 The masking value set with this command remains valid until the setting is changed or the power is turned off. All bits are masked (0) when the power is turned on, regardless of the previous setting.
*STB?	Returns the status byte register and MSS.	
	Setting command	None. Query only.
	Query command	*STB?
	Response example	32 The bits set with the *SRE command are only returned in decimal. The status byte register is not cleared even if a query is made using this command.

标准事件寄存器(ESR, ESE)

介绍

标准事件寄存器用*SRE, *ESE?和*ESR?指令/查询控制。

Bit	Data	Item	Description	Initial ESR value	Initial ESE value
7	128	PON	Power On flag	1 (Power ON)	0
6	64	-	Unused.	0	0
5	32	CME	Command error	0	0
4	16	EXE	Execution error	0	0
3	8	ALM	Alarm occurrence	0	0
2	4	-	Unused.	0	0
1	2	-	Unused.	0	0
0	1	OPC	Operation complete	0	0

Item	Description	
*ESE	Sets or inquires about the standard event status enable register.	
	Setting command	*ESE <value> The <value> range is from 0 to 255.
	Application example	*ESE 48 Enables the CME (bit 5) and EXE (bit 4) of the Event Status register.
	Query command	*ESE?
	Response example	48 The masking set with this command remains valid until the setting is changed or power is turned off. All bits are masked (0) when power is turned on, regardless of the previous setting.
*ESR?	Inquires about the Standard Event Status register.	
	Setting command	None. Query only.
	Query command	*ESR?
	Response example	32

		Bit 5 is set indicating that a command error has occurred. The ESR is cleared after reading the value.
--	--	--

状态字节寄存器的功能

介绍 如果事件发生且状态字节寄存器的某些位设成 1，那么 bit 6 设成 1 且发送一个服务请求(SRQ)。如下显示的四个状态位是 PSB-2000 中 SRQ 的发生原因。

如果执行错误，标准事件寄存器(ESR)的 bit 4 设成 1。当 ESR 和 ESE 中的布朗型 AND 等于 1，状态字节寄存器的 bit 5 (ESB)设成 1。如果此时服务请求使能寄存器(SRE)的 bit 5 设成 1，那么状态字节寄存器的 bit 6 (MSS)设成 1 并产生一个服务请求(SRQ)。

Bit 5	ESB	Standard event status register summary
Bit 4	MAV	Message available
Bit 1	LERR	Local bus execution error
Bit 0	TMO	Local bus time-out



注意

SRQ 仅通过 GPIB 接口传达

从状态字节寄存器读取数据和清除状态字节寄存器

介绍 状态字节寄存器的内容可以依如下两种方式从控制器中读出:

- 执行*STB?查询
当执行*STB?查询时，返回 MSS 位的状态。读取后并不清除状态字节的位。
- 串行查询

当执行串行查询时，返回 RQS 位(bit 6)的状态。
RQS 位仅在读取后清除。不能读取 MSS 位。不能直接清除状态字节寄存器；为了清除状态字节寄存器，用户必须首先清除引发设置状态字节寄存器位的相关事件寄存器。

- 执行 ESB 查询
当执行*ESR?查询时，读取标准事件寄存器中的数据，并清除所有位。
- 接收*CLS 指令
当接收到*CLS 指令时，PSB-2000 系列电源清除标准事件寄存器和状态字节寄存器
- MAV
当从输出序列读取所有数据时，清除 MAV 位

*CLS 指令不能清除输出序列
当完全清除事件寄存器和 MAV 时，MSS bit 6 也被清除

清除和重设状态

介绍 通过发送指令或执行特殊操作，PSB-2000 系列电源可以进行清除和重设操作。

IFC 一般指令、IFC 显示如下：

- (Interface clear)
- The specified talker or listener status is cleared.
 - The GPIB buffer, output queue and input queued commands command remain unchanged.
 - The SRQ remains unchanged.
 - The remote status and LLO (local lock out)

setting remain unchanged.

- Panel setting remains unchanged.

DCL SDC 一般指令、DCL 和地址指令、SDC 显示如下：

(Device clear)

- The GPIB buffer, output queue and input queued commands are cleared.
- The interface status (specified talker or listener status) is cleared.
- The SRQ and status byte register are cleared.
- The remote status and LLO (local lock out) setting are cleared and the power supply unit enters the local state.
- Panel setting remains unchanged.

- *RST (Reset command)
- IEEE488.2 指令、*RST 显示如下：
- The specified talker or listener status is cleared.
 - The GPIB buffer, output queue and input queued commands are cleared.
 - The SRQ, status byte register and mask settings are cleared.
 - The remote status and LLO (local lock out) setting remain unchanged.
 - Panel setting remains unchanged.
-

- Turning on power again
- 再次开机，状态显示如下：
- The specified talker or listener status is cleared.
 - The GPIB buffer, output queue and input queued commands are cleared.
 - The SRQ, status byte register and mask settings are cleared.
 - The unit enters the local status. The LLO (local lock out) set before turning off power is cleared.
 - Panel setting at the time when power is turned off remains unchanged.

远程/本地功能

- 介绍 通过系统控制器和 PSB-2000 系列电源上的 **FAST** 键控制远程/本地功能(该键作为 FAST, LOCK 和 LOCAL 键)。PSB-2000 系列电源总是处于本地、远程或远程兼本地封锁状态。
- 本地 PSB-2000 系列电源可以以如下两种方式进入本地状态：
- 开机
 - 按 **FAST** 键，该键侧方的 LED 变亮
 - 电源接收 GTL 指令
 - 取消远程状态
- 远程 在 REN 为 true 的条件下，当它定作为 listener ，PSB-2000 系列电源供应器进入远程控制模式 ，LED 显示进入远程显示模式，此时除 POWER 开关和 **FAST** 键之外，任何面板键都是无效的。在本地封锁状态下，除 POWER 开关之外任何键都是无效的，除非仪器发生故障。

多行消息指令

介绍 如下表格显示了多行消息指令和其响应。

Type	Name	Description	Response
Universal commands	DCL	Clears the GP-IB buffer.	○
	SPE	Establishes the serial polling state.	○
	SPD	Clears serial polling.	○
	PPU	Clears parallel polling.	×
	LLO	Brings all devices into the local lockout status to disable manual operation.	○
Address commands	UNL	Cancels the specified listener status.	○
	UNT	Cancels the specified talker status.	○
	SDC	Clears the GPIB buffer.	○
	PPC	Enables parallel polling line assignment to the specified listener in parallel polling.	×
	GTL	Brings a specified device into the local status.	○
	GET	Triggers a specified device.	×
	TCT	Transfers the controller.	×

附录

故障排除

概述 该部分介绍一些常见问题和解决办法。

绝大多数问题都可以通过重新连接、设置或其它简单操作解决。如果问题仍存在，请联系您最近的经销商。请勿自行拆机检查。

问题	可能原因	检测和解决方法
Power is not turned on, even after pressing the POWER switch.	• AC power cable is broken or has poor contact.	• Check connection or replace the cable.
	• Input fuse has blown.	• Input voltage is out of the allowable range.
"----" is displayed after starting operation.	The unit is specified as a slave unit.	Specify the unit as the master unit. See page 66, "Master/slave function".
"OHP" is displayed after starting operation.	The OHP function works.	Check the ambient temperature, air intake and exhaust ports and dust filter.
Display disappears in short time after starting operation.	The fan is stopping.	Check the fan.
No output is given even when the OUTPUT key is pressed.	• The set voltage is "0V".	• See page 42, "How to set voltage" . See page 73, "Constant-voltage control with external voltage or resistance".
	• The set current is "0A". (In	• See page 43, "How to set

	the CC status)	current". See page 75, "Constant-current control with external voltage or resistance."
	<ul style="list-style-type: none"> • On/Off with the external contacts is selected. • The channel output key is not selected or an incorrect channel is selected for output. • Keys are locked. 	<ul style="list-style-type: none"> • See page 76, "Output On/Off with external contacts". • See page 44, "How to output". • See page 47, "How to disable panel operations".
"OVP" is displayed when the OUTPUT key is pressed.	• The OVP value is too low.	• See page 50, "OVP/OCP function".
	• The sensing wire(s) is/are disconnected.	• See page 68, "Voltage Remote Sensing".
	• The resistor is open in the external resistance control mode.	• See page 73, "Constant-voltage control with external voltage or resistance".
"OCP" is displayed when the OUTPUT key is pressed.	• The OCP value is too low.	See page 50, "OVP/OCP function".
Cannot raise the current up to the set current value.	CP (constant-power) operation is being used, or the CP value is too low.	See page 43, "How to set power".
Output is unstable.	Oscillating due to influences of the load.	<ul style="list-style-type: none"> • Twist the load or sensing wires, or change the wire layout. • Connect a capacitor at the output end of the power source or the load end.
Output voltage does not fall.	The Hi- Ω function is activated.	See page 53, "Hi- Ω function".

维修

介绍

PSB 系列电源使用风扇制冷。

定期用水清洁滤尘器，维持制冷效果。按上部的凹槽，移除盖板。在移除前，必须关机并切断 AC 电源。



注意

在重新安装前确保滤尘器完全晾干，否则会引发故障。

PSB-2400L
PSB-2400L2
PSB-2800L
PSB-2400H
PSB-2800H

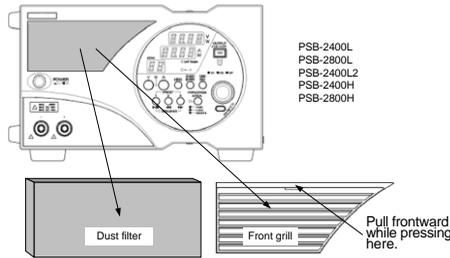

PSB-2800LS

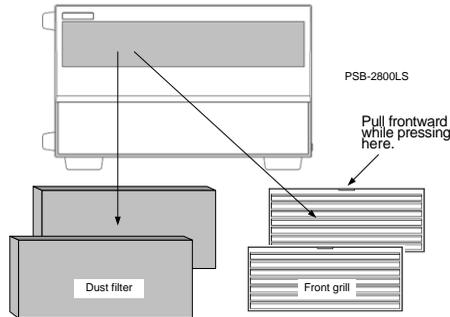

尺寸

PSB--2400L, PSB-2400L2, PSB-2800L

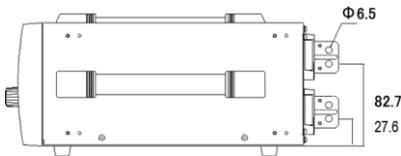
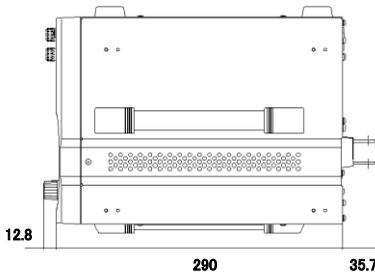
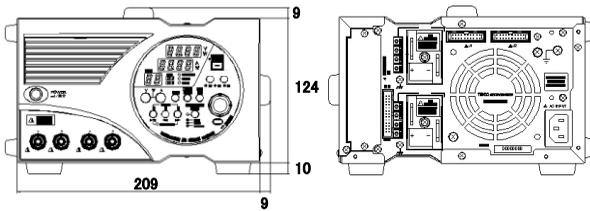

PSB-2800LS

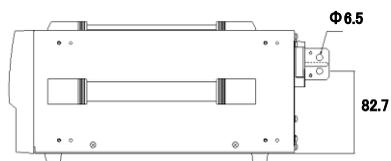
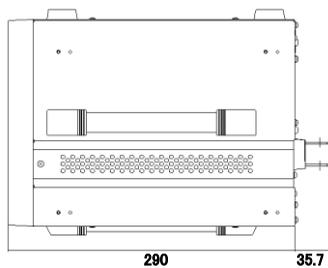
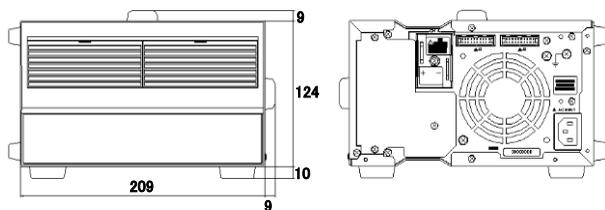

PSB-2400H, PSB-2800H

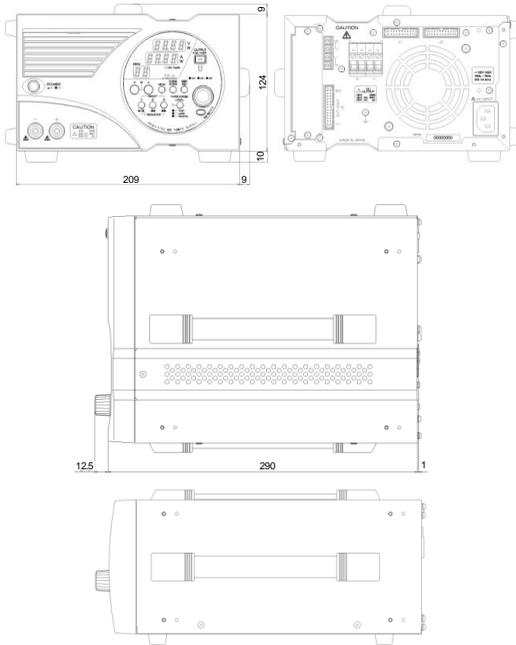

规格

输出

型号	PSB-2400L	PSB-2800L	PSB-2400L2	PSB-2800LS
额定输出电压	80.00V	80.00V	80.00V×2CH	80.00V
设置精度	0.1%设定值±2位(23°C ±5°C)			
分辨率	10mV			
显示精度	0.2%读值±2位(23°C ±5°C)			
额定输出电流 ¹	40.00A	80.00A	40.00A×2CH	80.00A
设置精度	0.2%设定值±2位(23°C ±5°C)			
分辨率	10mA			
显示精度	0.3%读值±2位(23°C ±5°C)			
额定输出功率 ²	400W	800W	400W×2CH	800W
设置精度	±10W			
分辨率	10W			
显示精度	0.5%读值±5位(23°C ±5°C)			

¹ 前输出端子的最大输出电流为 40A

² 从定电压(CV)或定电流(CC)模式切换到定功率(CP)模式会受过载的影响，反之亦然

型号	PSB-2400H	PSB-2800H
额定输出电压	800.0V	
设置精度	0.1%设定值 ± 2 位(23°C $\pm 5^\circ$ C)	
分辨率	100mV	
显示精度	0.2%读值 ± 2 位(23°C $\pm 5^\circ$ C)	
额定输出电流 ¹	3.00A	6.00A
设置精度	0.2% setting ± 2 digit (23°C $\pm 5^\circ$ C)	
分辨率	10mA	
显示精度	0.3% reading ± 2 digit (23°C $\pm 5^\circ$ C)	
额定输出功率 ²	400W	800W
设置精度	± 10 W	
	Output voltage should be at least 1% of the rated voltage	
分辨率	10W	
显示精度	0.5% reading ± 5 digit (23°C $\pm 5^\circ$ C)	

¹ 前输出端子的最大输出电流为 3A(2400H)或 6A(2800H)

² 从定电压(CV)或定电流(CO)模式切换到定功率(CP)模式会受到过载的影响, 反之亦然

输入

型号	PSB-2400L, PSB-2400H	PSB-2800L, PSB-2400L2, PSB-2800LS, PSB-2800H
输入电压	AC100V~240V, 单相, 频率: 50Hz/60Hz	
功率损耗 ³	560VA	1120VA
功率因数 ⁴	0.99	
突波电流	35A max.	70A max.

^{3,4} 在额定输出电压和 AC100V 输入时

定电压特性

型号	PSB-2400L	PSB-2800L	PSB-2400L2
电源变动率 ⁵	0.01%额定电压 \pm 2mV		
负载变动率 ⁶	0.01%额定电压 \pm 3mV		
纹波噪声(p-p) ⁷	90mV	150mV	90mV
纹波噪声(rms) ⁸	4mV	6mV	4mV
瞬态响应(typ.) ⁹	1ms	1ms	1ms
上升时间(typ.) ¹⁰	50ms (额定负载), 50ms (空载)		
下降时间(typ.) ¹¹	100ms (额定负载), 500ms (空载)		
温度系数(typ.) ¹²	\pm 50ppm/ $^{\circ}$ C (热机 30min)		

型号	PSB-2400H	PSB-2800H
电源变动率 ⁵	0.01%额定电压 \pm 20mV	
负载变动率 ⁶	0.01%额定电压 \pm 30mV	
纹波噪声(p-p) ⁷	250mV	300mV
纹波噪声(rms) ⁸	20mV	25mV
	(当电流小于等于 2A)	
纹波噪声(rms) ⁸	35mV	40mV
	(当电流大于 2A)	
	输出电压至少应是额定电压的 1%	
瞬态响应(typ.) ⁹	7ms	
上升时间(typ.) ¹⁰	200ms (额定负载), 200ms (空载)	
下降时间(typ.) ¹¹	500ms (额定负载), 1000ms (空载)	
温度系数(typ.) ¹²	\pm 100ppm/ $^{\circ}$ C (热机 30min)	

定电流特性

型号	PSB-2400L	PSB-2800L	PSB-2400L2
电源变动率 ⁵	0.01%额定电压±2mV		
负载变动率 ¹³	0.01%额定电压±3mV		
纹波噪声(rms)	30mA	60mA	30mA
温度系数(typ.) ¹²	±100ppm/°C (热机 30min)		

型号	PSB-2400H	PSB-2800H
电源变动率 ⁵	0.05%额定电压±10mV	
负载变动率 ¹³	0.05%额定电压±15mV	
纹波噪声(rms)	15mA	20mA
温度系数(typ.) ¹²	±200ppm/°C (热机 30min)	

定功率特性

型号	PSB-2400L, PSB-2800L, PSB-2400L2, PSB-2400H, PSB-2800H
电源变动率 ⁵	0.5% ±10W

⁵ 电源电压在 AC100V~240V 范围内改变±10%时引起的输入电压波动

⁶ 额定输出电压时，负载从额定负载变成空载(开路)时引起的输入电压波动

⁷ 在 20 MHz 的测量值

⁸ 在 1 MHz 的测量值(PSB-2400H, PSB-2800H 为 300kHz)

⁹ Response time till the output voltage is restored to the range within 0.1% + 10 mV of the rated output voltage when the output current is changed from 50% to 100% of the maximum output current at the rated output voltage.

¹⁰ 固定负载。输出电压从额定电压的 10%增至 90%所需要的时间

¹¹ 固定负载。输出电压从额定电压的 90%降至 10%所需要的时间

¹² 在热机 30min 后(除外部控制)

¹³ 额定输出电流时，负载从额定负载变成空载(短路)时引起的输入电压波动

功能

定电压(CV) 控制外部电压	输出电压: 约 0V~额定输出电压 对应外部电压: 0V~10V
定电压(CV) 控制外部电阻	输出电压: 约 0V~额定输出电压 对应外部电阻: 0Ω~10KΩ
定电流(CC) 控制外部电压	输出电流: 约 0A~额定输出电流 对应外部电压: 0V~10V
定电流(CC) 控制外部电阻	输出电流: 约 0A~额定输出电流 对应外部电阻: 0Ω~10kΩ
外部 On/Off 控制	On/Off 切换. Short: On, Open: Off
输出电压监控信号	约 0V~10V 对应 0V~额定输出电压
输出电流监控信号	约 0V~10V 对应 0A~额定输出电流
定电压(CV) 状态信号	开路集电极, 低电平有效
定电流(CC) 状态信号	开路集电极, 低电平有效
报警信号输出	开路集电极, 低电平有效
报警信号输入	短路时关闭输出
远程传感功能	在电源的两个终端, 额定电压范围内最多可补偿 1V 压降(单侧)
并联机柜连接操作	最多 4 台(PSB-L 系列) 最多 2 台(PSB-H 系列)
串联机柜连接操作	最多 2 台(PSB-L 系列)
预设功能	最多可预先设置三点 可预先设置输出断开的时间 设置范围: 10min~99hrs. & 50min
关闭定时器(OFF TIMER)功能	
高阻(HI-Ω)功能	断开内部分压电路(仅适合 PSB-L 系列)
延迟(DELAY)功能	输出延迟时间可预先设置. 设置范围: -9.99s~10.00s. (分辨率: 0.01sec.) (仅适合 PSB-L 系列)
追踪功能 ¹⁴	可能同时改变两个通道的输出设置
按键锁定功能	前面板不能工作 步骤数: 0~99 步骤时间: 1~9999 (s) 周期数: 1~999 (-: 无限次)
序列功能	使用 PSB_Sequence_203 软件, 产品可进行简单的编程操作 有关序列操作的软件可以从 GWInstek 官网下载

¹⁴ 仅适合 PSB-2400L2

保护功能

过电压保护(OVP): 固定 ¹⁵	当输出电压超过额定电压的 110%时停止。(输出关闭) 可预设范围: 前面板 1V~84V.(PSB-L 系列)
过电压保护(OVP): 可调 ¹⁶	可预设范围: 前面板 1V~840V.(PSB-H 系列) OVP 工作时停止。(输出关闭)
过电流保护(OCP): 固定 ¹⁵	当输出电流超过额定电流的 110%时停止。(输出关闭) 可预设范围: 前面板 1A~42A.(PSB-L 系列)
过电流保护(OCP): 可调 ¹⁶	可预设范围: 前面板 0.1A~3.15A.(2400H) 可预设范围: 前面板 0.1A~6.3A.(2800H) OCP 工作时停止。(输出关闭) (2800L: 84A)
过热保护(OHP) ¹⁵	当内部散热器温度超过热敏开关值时, 机器停止

¹⁵ 再按 POWER 开关重设

¹⁶ 再按 POWER 开关或按 ESC 键重设

其它

制冷方式	风扇马达制冷
To-GND 电压	±DC500V(PSB-L 系列) ±DC100V(PSB-H 系列)
耐压强度	Power In terminals – 机框: AC1500V, 1min. Power In terminals – 输出端: AC2300V, 1min. Power In terminals – 机框: DC500V(PSB-L), DC1000V(PSB-H), 30MΩ 以上
绝缘电阻	Power In terminals – 输出端: DC500V(PSB-L), DC1000V(PSB-H), 30MΩ 以上。(PSB-L) 输出端 – 机框: DC500V(PSB-L), DC1000V(PSB-L), 30MΩ 以上
外部尺寸 (不含外包装)	210mm(W)×124mm(H)×290mm(D)
重量	PSB-2400L, PSB-2400H: 约 5kg PSB-2800L, PSB-2400L2, PSB-2800LS: 约 7kg PSB-2800H: 约 6kg

环境条件

工作温度范围	0°C~+40°C
工作湿度范围	30% RH~80% RH (无凝结)
存储温度范围	-20°C~+70°C
存储湿度范围	30% RH~80% RH (无凝结)

适用标准

LVD		EN61010-1 2 nd 版本(2001)
		室内使用
		海拔 2000m
		瞬态电压: 过压等级 II
		污染等级 2
		EN61000-3-2 clause 7.1 class A
		EN61000-3-3 clause 5
EMC	EMS (Min)	EN61326-1 : 2006
	EMI(Class A)	EN61326-1 : 2006

❖ 该标准仅适合后面板标识 CE 认证的产品, 改进产品不适用

默认设置和关机保存

项目	初始设置	关机存储
电压	0.00V	○
电流	0.00A	○
功率	410W/820W	○
OVP	84.00V(PSB-L 系列)	○
	840.0V(PSB-H 系列)	
OCP	42.00A/84.00A(PSB-L 系列)	○
	3.15A/6.30A (PSB-H 系列)	
显示模式	CH1(V/A)	○
菜单显示	关机时初始化	×
操作模式	V	○
外部电压控制	OFF	○
外部电阻控制	OFF	○
外部输出 on/off	IN	○
预设功能	OFF	○
预设项: 电压	0V	○
预设项: 电流	0A	○

预设项: 功率	410W/820W	○
Off-timer 功能	OFF	○
高阻功能	OFF	○
高阻保持时间	30min	○
延迟功能	OFF	○
后延延迟时间	0	○
下降延迟时间	0	○
追踪功能	OFF	○
序列功能	OFF	○
序列起始 No.	0	○
序列结束 No.	99	○
序列重复率	1	○
序列项: 电压	0V	○
序列项: 电流	41.00A/82.00A(PSB-L 系列) 3.07A/6.15A (PSB-H 系列)	○
序列项: 功率	410W/820W	○
序列项: 输出	OFF	○
序列项: 时间	1s	○
按键锁定功能	OFF	×
One-control 操作	OFF	○
输出状态	关机时初始化	×
序列操作状态	×(停止状态)	×
Off-timer 操作状态	×(无操作状态)	×
系统地址	1	○
PC 机地址	3	○

并联/串联操作设置表

PSB-2400H

项目	单台	并联
	400H	400H x 2
400W	800W	

电压设置	SLOW	100mV	
	FAST	10V	
	范围	0V~820V	
	最小显示位	100mV	
电流设置	SLOW	10mA	100mA
	FAST	1A	1A
	范围	0A~3.07A	0A~6.1A
	最小显示位	10mA	
功率设置	SLOW	10W	20W
	FAST	100W	200W
	范围	10W~410W	20W~820W
	最小显示位	1W	
OVP 设置	SLOW	1V	
	FAST	100V	
	范围	10V~840V	
	最小显示位	100mV	
	SLOW	10mA	20mA
	FAST	1A	2A
	范围	0.1A~3.15A	0.2A~6.3A
	最小显示位	10mA	10mA

并联时，电流可以显示的最小值是 100mA(最小显示位)，因此实际电流的设置分辨率可能与显示分辨率不同。这种情况下，仅一个编码器或许不能更新显示屏

PSB-2800H

项目		单台	并联
		800H	800H x 2
		800W	1600W
电压设置	SLOW	100mV	
	FAST	10V	
	范围	0V~820V	
	最小显示位	100mV	
电流设置	SLOW	10mA	100mA
	FAST	1A	1A
	范围	0A~6.15A	0A~12.3A
	最小显示位	10mA	100mA
功率设置	SLOW	10W	20W
	FAST	100W	200W
	范围	10W~820W	20W~1640W
	最小显示位	1W	
OVP 设置	SLOW	1V	
	FAST	100V	
	范围	10V~840V	
	最小显示位	100mV	
	SLOW	10mA	20mA
	FAST	1A	2A
	范围	0.1A~6.3A	0.2A~12.6A
	最小显示位	10mA	10mA

并联时，电流可以显示的最小值是 100mA(最小显示位)，因此实际电流的设置分辨率可能与显示分辨率不同。这种情况下，仅一个编码器或许不能更新显示屏

PSB-2400L (Part 1/2)

项目	单台	并联		
	2400L	2400L x 2	2400L x 3 2400L + 2800L	2400L x 4
	400W	800W	1200W	1600W
电压设置				
SLOW	10mV			
FAST	1V			
范围	0V~82V			
最小显示位	10mV			
电流设置				
SLOW	10mA	100mA	90mA	80mA
FAST	1A	10A	9A	8A
范围	0A-41A	0A-82A	0A-123A	0A-164A
最小显示位	10mA	100mA		
功率设置				
SLOW	10W	100W	99W	100W
FAST	100W	1000W	990W	1000W
范围	10W-410W	20W-820W	30W-1230W	40W-1640W
最小显示位	1W			
OVP 设置				
SLOW	100mV			
FAST	10V			
范围	1V-84V			
最小显示位	10mV			
OCP 设置				
SLOW	100mA	200mA	300mA	400mA
FAST	10A	20A	30A	40A
范围	1A-42A	2A-84A	3A-126A	4A-168A
最小显示位	10mA	100mA		

并联时，电流可以显示的最小值是 100mA(最小显示位)，因此实际电流的设置分辨率可能与显示分辨率不同。这种情况下，仅一个编码器或许不能更新显示屏

PSB-2400L (Part 2/2)

项目	并联			串联
	2400L+ 2800L x 2	2400L + 2400L + 2800L x 2	2400L + 2800L x 3	2400L + 2400L
	2000W	2400W	2800W	800W
电压设置				
SLOW	10mV			
FAST	1V			
范围	0V~82V			
最小显示位	10mV			
电流设置				
SLOW	100mA	60mA	70mA	10mA
FAST	10A	6A	7A	1A
范围	0A-205A	0A-246A	0A-287A	0A-41A
最小显示位	100mA			10mA
功率设置				
SLOW	100W	96W	98W	10W
FAST	1000W	960W	980W	100W
范围	50W-2050W	60W-2460W	70W-2870W	10W-410W
最小显示位	1W			
OVP 设置				
SLOW	100mV			
FAST	10V			
范围	1V-84V			
最小显示位	10mV			
OCP 设置				
SLOW	500mA	600mA	700mA	100mA
FAST	50A	60A	70A	10A
范围	5A-210A	6A-252A	7A-294A	1A-42A
最小显示位	100mA			10mA

并联时，电流可以显示的最小值是 100mA(最小显示位)，因此实际电流的设置分辨率可能与显示分辨率不同。这种情况下，仅一个编码器或许不能更新显示屏

PSB-2800L

项目	单台	并联			串联
	800L	800L x 2	800L x 3	800L x 4	800L + 800L
	800W	1600W	2400W	3200W	1600W
电压设置					
SLOW	10mV				
FAST	1V				
范围	0V-82V				
最小显示位	10mV				
电流设置					
SLOW	10mA	100mA	90mA	80mA	10mA
FAST	1A	10A	9A	8A	1A
范围	0A-82A	0A-164A	0A-246A	0A-328A	0A-82A
最小显示位	10mA	100mA			10mA
功率设置					
SLOW	10W	100W	99W	100W	10W
FAST	100W	1000W	990W	1000W	100W
范围	10W-820W	20W-1640W	30W-2460W	40W-3280W	10W-820W
最小显示位	1W				
OVP 设置					
SLOW	100mV				
FAST	10V				
范围	1V-84V				
最小显示位	10mV				
OCP 设置					
SLOW	100mA	200mA	300mA	400mA	100mA
FAST	10A	20A	30A	40A	10A
范围	1A-84A	2A-168A	3A-252A	4A-336A	1A-84A
最小显示位	10mA	100mA			10mA

并联时，电流可以显示的最小值是 100mA(最小显示位)，因此实际电流的设置分辨率可能与显示分辨率不同。这种情况下，仅一个编码器或许不能更新显示屏

Declaration of Conformity

We

GOOD WILL INSTRUMENT CO., LTD.

(1) No.7-1, Jhongsing Rd., Tucheng City, Taipei County, Taiwan

(2) No. 69, Lu San Road, Suzhou City (Xin Qu), Jiangsu Sheng, China

declare, that the below mentioned product

Type of Product: Multi-Range Bench-Top DC Power Supply

Model Number:PSB-2400L, PSB-2800L, PSB-2400L2, PSB-2800LS

are herewith confirmed to comply with the requirements set out in the

Council Directive on the Approximation of the Law of Member States

relating to Electromagnetic Compatibility (2004/108/EC) and Low

Voltage Directive (2006/95/EC).

For the evaluation regarding the Electromagnetic Compatibility and

Low Voltage Directive, the following standards were applied:

© EMC	
EN 61326-1: Electrical equipment for measurement, control and laboratory use -- EMC requirements (2006)	
Conducted Emission	Electrostatic Discharge
Radiated Emission	IEC 61000-4-2: 2008
CISPR11: 2003+A1: 2004+A2: 2006	
Current Harmonics	Radiated Immunity
EN 61000-3-2:	IEC 61000-4-3: 2008
2006+A1:2009+A2:2009	
Voltage Fluctuations	Electrical Fast Transients
EN 61000-3-3: 2008	IEC 61000-4-4: 2004 +A1:2010
-----	Surge Immunity
	IEC 61000-4-5: 2005
-----	Conducted Susceptibility
	IEC 61000-4-6: 2008
-----	Power Frequency Magnetic Field
	IEC 61000-4-8: 2009
-----	Voltage Dip/ Interruption
	IEC 61000-4-11: 2004

© Safety

Low Voltage Equipment Directive 2006/95/EC	
Safety Requirements	IEC/EN 61010-1: 2001